



Henny Penny High Volume Open Fryer

Model OFE/OFG-341
Model OFE/OFG-342
Model OEA/OGA-341
Model OEA/OGA-342

TECHNICAL MANUAL

NOTICE

This manual should be retained in a convenient location for future reference.

A wiring diagram for this appliance is located on the inside of the right side panel.

Post in a prominent location, instructions to be followed in event user smells gas. This information shall be obtained by consulting the local gas supplier.

Do not obstruct the flow of combustion and ventilation air. Adequate clearance must be left all around appliance for sufficient air to the combustion chamber.

The Model OFG/OGA-34X open fryer is equipped with a continuous pilot. But the open fryer can not be operated without electric power. The unit will automatically return to normal operation when power is restored.

CAUTION

To avoid a fire, keep appliance area free and clear from combustibles.



Improper installation, adjustment, alteration, service or maintenance can cause property damage, injury or death. Read the installation, operating and maintenance instructions thoroughly before installing or servicing this equipment.



FOR YOUR SAFETY, DO NOT STORE OR USE GASOLINE OR OTHER FLAMMABLE VAPORS AND LIQUIDS IN THE VICINITY OF THIS OR ANY OTHER APPLIANCE.

TABLE OF CONTENTS

Section	Page
Section 1. TROUBLESHOOTING	1-1
1-1. Introduction	1-1
1-2. Safety	1-1
1-3. Troubleshooting	1-2
1-4. Error Codes	1-4
 Section 2. MAINTENANCE	 2-1
2-1. Introduction	2-1
2-2. Maintenance Hints	2-1
2-3. High Temperature Limit Control (Gas Units).....	2-1
2-4. Complete Control Panel Replacement	2-4
2-5. Power Switch	2-4
2-6. Temperature Probe Replacement (Gas)	2-5
2-7. Temperature Probe Replacement (Electric).....	2-6
2-8. Flame Sensor/Pilot/Ignitor Assembly (Gas)	2-7
2-9. Ignition Module.....	2-9
2-10. Transformer Replacement.....	2-10
2-11. Control & I/O Boards Replacement.....	2-10
2-12. Vacuum Switch Replacement	2-11
2-13. Drain Microswitch Replacement	2-12
2-14. Filter Switch Replacement	2-12
2-15. Gas Control Valve Replacement.....	2-13
2-16. Blower Motor Replacement	2-15
2-17. Heating Elements (Electric)	2-17
2-18. Heating Contactors (Electric).....	2-19
2-19. Speaker Assembly.....	2-22
2-20. High Temperature Limit Control (Electric)	2-23
2-21. Filter Pump and Motor Removal	2-26
2-22. Autolift Transformer Replacement (if applicable).....	2-27
2-23. Autolift PC Board Replacement (if applicable).....	2-28
2-24. Autolift Actuator (Motor) Replacement (if applicable).....	2-28
Wiring Diagrams	

SECTION 1. TROUBLESHOOTING

1-1. INTRODUCTION

This section provides troubleshooting information in the form of an easy to read table.

If a problem occurs during the first operation of a new fryer, recheck the Installation Section of the Operator's Manual.

Before troubleshooting, always recheck the Operation Section of the Operator's Manual.

1-2. SAFETY

Where information is of particular importance or is safety related, the words DANGER, WARNING, CAUTION, or NOTE are used. Their usage is described on the next page:



SAFETY ALERT SYMBOL is used with DANGER, WARNING or CAUTION which indicates a personal injury type hazard.



NOTICE is used to highlight especially important information.



CAUTION used without the safety alert symbol indicates a potentially hazardous situation which, if not avoided, may result in property damage.



CAUTION used with the safety alert symbol indicates a potentially hazardous situation which, if not avoided, could result in minor or moderate injury.



WARNING indicates a potentially hazardous situation which, if not avoided, could result in death or serious injury.



DANGER INDICATES AN IMMINENTLY HAZARDOUS SITUATION WHICH, IF NOT AVOIDED, WILL RESULT IN DEATH OR SERIOUS INJURY.

1-3. TROUBLESHOOTING

To isolate a malfunction, proceed as follows:

1. Clearly define the problem or symptom and when it occurs.
2. Locate the problem in the Troubleshooting table.
3. Review all possible causes, then one at a time work through the list of corrections until the problem is solved.



If maintenance procedures are not followed correctly, injuries and/or property damage could result.

PROBLEM	CAUSE	CORRECTION
With the switch in the ON position, fryer is completely inoperative	<ul style="list-style-type: none"> • Open circuit 	<ul style="list-style-type: none"> • Check to see if unit is plugged in • Check breaker or fuse at supply box • Check power switch per Power Switch Section; replace if defective • Check voltage at wall receptacle • Check cord and plug
Shortening will not heat but lights are on	<ul style="list-style-type: none"> • Faulty contactor (elec. Model) • Faulty gas control valve (gas model) • Faulty temperature probe • Faulty high limit • Faulty drain switch 	<ul style="list-style-type: none"> • Check contactor per Heating Contactors Section • Check gas control valve per Gas Control Valve Assembly Section • Check temperature probe per Temperature Probe Replacement Section; “E6” • Check high limit per the appropriate High Temperature Limit Control Section; “E10” • Check drain switch per Drain Microswitch Section; “E15”

1-3. TROUBLESHOOTING (Continued)

PROBLEM	CAUSE	CORRECTION
Heating of shortening too slow	<ul style="list-style-type: none"> • Low or improper voltage (elec. unit) • Weak or burnt out elements (elec. unit) • Wire(s) loose • Burnt or charred wire connection • Faulty contactor • Supply line too small – low gas volume (gas unit) • Improper ventilation 	<ul style="list-style-type: none"> • Use a meter and check the receptacle voltage against the data plate • Check heating elements per Heating Elements Section • Tighten • Replace wire and clean connectors • Check contactor per Heating Contactors Section • Increase supply line size; refer to Installation Section of Operator’s Manual • Refer to Installation Section of Operator’s Manual
Shortening overheating	<ul style="list-style-type: none"> • Temperature probe needs calibrated • Mercury contactor stuck closed • bad control board 	<ul style="list-style-type: none"> • Calibrate temperature probe if $\pm 10^\circ$ off; if more than $\pm 10^\circ$ off, replace temperature probe • Check mercury contactor for not opening; replace if necessary (elec. unit) • Replace control board if heat indicator stays on past ready temperature
Foaming or boiling over of shortening	<ul style="list-style-type: none"> • Water in shortening • Improper or bad shortening • Improper filtering • Improper rinsing after cleaning the fryer 	<ul style="list-style-type: none"> • At end of cook cycle, drain shortening and clean • Use recommended shortening • Refer to the Filtering the Shortening Section in Operator’s Manual • Clean and rinse the frypot; then dry thoroughly

1-2. TROUBLESHOOTING
(Continued)

PROBLEM	CAUSE	CORRECTION
Shortening will not drain from frypot	<ul style="list-style-type: none"> • Drain valve clogged with crumbs • Drain valve will not open by turning handle 	<ul style="list-style-type: none"> • Open valve, force cleaning brush through drain • Replace cotter pins in valve coupling
Filter motor runs but pumps shortening slowly	<ul style="list-style-type: none"> • Pump clogged • Filter line connection loose • Solidified shortening in lines 	<ul style="list-style-type: none"> • Remove pump cover and clean • Tighten all filter line connections • Clear all filter lines of solidified shortening
Filter switch on, motor does not run	<ul style="list-style-type: none"> • Defective switch • Defective motor • Motor thermal protector tripped 	<ul style="list-style-type: none"> • Check/replace switch per Filter Switch Section • Check/replace motor • Reset thermal switch on filter motor
Motor hums but will not pump	<ul style="list-style-type: none"> • Clogged lines or pump 	<ul style="list-style-type: none"> • Remove and clean pump lines • Replace pump seal, rotor and roller

1-4. ERROR CODES

In the event of a control system failure, the digital display shows An error message. These messages are coded: “E4”, “E5”, “E6”, “E10”, “E15”, “E20”, “E31”, “E41”, “E46”, and “E92”. A Constant tone is heard when an error code is displayed, and to silence this tone, press any button.

DISPLAY	CAUSE	PANEL BOARD CORRECTION
“E-4”	Control board overheating	Turn switch to OFF position, then turn switch back to ON; if display shows “E4”, the control board is getting too hot; check the louvers on each side of the unit for obstruction
“E-5”	Shortening overheating	Turn switch to OFF position, then turn switch back to ON; if display shows “E5”, the heating circuits and temperature probe should be checked
“E-6A”	Temperature probe open	Turn switch to OFF position, the turn switch back to ON; if display shows “E6”, the temperature probe should be checked
“E-6B”	Temperature probe shorted	Turn switch to OFF position, the turn switch back to ON; if display shows “E6”, the temperature probe should be checked to replace, per Temperature Probe Replacement Section
“E-10”	High limit	Reset the high limit by manually pushing up on the red reset button; if high limit does not reset, high limit must be replaced per High Limit Temperature Control Section
“E-15”	Drain switch failure	Close drain, using the drain valve handle; if display still shows “E-15”, check the drain microswitch per Drain Microswitch Section
“E-31”	Elements not hinged all the way down	Check to make sure the elements are hinged all way down into the frypot; check for obstructions under elements way down
“E-41” “E-46”	Programming failure	Turn switch to OFF, then back to ON; if display shows any of the error codes, try to reinitialize the control (Special Program Mode Section of Operator’s Manual); if error code persists, replace the control panel per Complete Control Panel Replacement Section

1-4. ERROR CODES
(Continued)

DISPLAY	CAUSE	PANEL BOARD CORRECTION
“E-20 A”	Vacuum switch failure (stuck closed)	Press the timer button to try the ignition process again, and if “E-20 A” persist, check the air switch per Vacuum Switch Section
“E-20 B”	Draft fan or vacuum switch failure (stuck open)	Press the timer button to try the ignition process again and if “E-20 B” persist, check the vacuum switch per Vacuum Switch Section or the blower motor per Blower Motor Assembly Section
“E-20 C”	Ignition modules not responding	Press the timer button to try the ignition process again; if “E-20 C” persists, check the ignition module per Ignitor Module Section, the spark ignitor per Pilot/Ignitor Module Section, the I/O board per Control & I/O Boards Section
“E-20 D”	Pilots not lit or no flame sense	Press the timer button to try the ignition process again; if “E-20 D” persists, check the ignition module per Ignition Module Section, the I/O board per Control & I/O Boards Section or the flame sense per Flame Sensor Section
“E-47”	Analog converter chip or 12 volt supply failure	Turn the switch to OFF, then turn back to ON; if “E-47) persists, replace the I/O board, or the PC board; if speaker tones are quiet, probably I/O board failure
“E-48”	Input system error	Replace PC board
“E-70”	Faulty power switch or switch wiring; faulty I/O board	Check power switch, along with its wiring; replace I/O board if necessary
“E-92”	24 VAC fuse on I/O open	Check for shorted component in 24 volt circuit; (i.e., high limit, drain switch, vacuum switch)

SECTION 2. MAINTENANCE

2-1. INTRODUCTION

This section provides procedures for the check out and replacement of the various parts used within the fryer. Before replacing any parts refer to the Troubleshooting Section. It will aid you in determining the cause of the malfunction.

2-2. MAINTENANCE HINTS

1. You may need to use a multimeter to check the electric components.
2. When the manual refers to the circuit being closed, the multimeter should read zero unless otherwise noted.
3. When the manual refers to the circuit being open, the multimeter will read infinity.

2-3. HIGH TEMPERATURE LIMIT CONTROL (Gas Units)

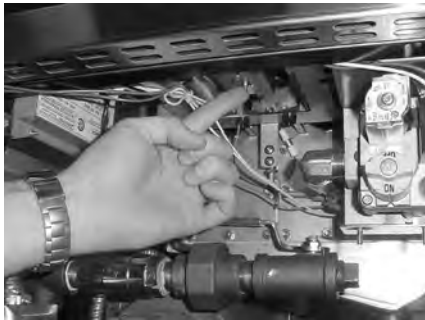

Figure 2-1

This high temperature control is a safety, manual reset control, which senses the temperature of the shortening. If the shortening temperature exceeds 425°F (218°C), this switch opens and shuts off heat to the frypot. When the temperature of the shortening drops to a safe operation limit, the control must be manually reset by pressing the red reset button. The red reset button is located under the control panel, in the front of the fryer. (Figure 2-1). This allows heat to be supplied to the frypot.

Before replacing a high temperature limit control, check to see that its circuit is closed.

NOTICE

The shortening temperature must be below 380°F (193°C) to accurately perform this check.

Checkout



Figure 2-2



To avoid electrical shock or property damage, move the power switch to OFF and disconnect main circuit breaker, or unplug cord at wall receptacle.

1. Remove the control panel. Figure 2-2.

**1-3. HIGH TEMPERATURE
LIMIT CONTROL
(Gas Units) (Continued)**

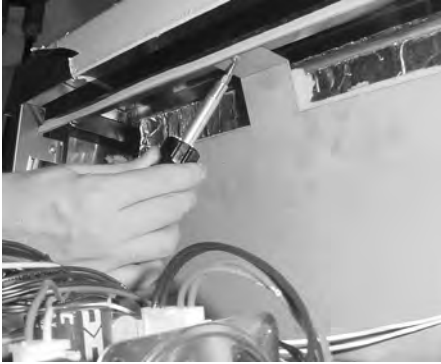

Figure 2-3

- Using a Phillip's head screwdriver, remove the screws securing the inner heat shield and remove from unit. Figure 2-3.



Figure 2-4

- Remove the screw securing the high limit bracket to the frame and remove the high limit and bracket from unit. Figure 2-4.

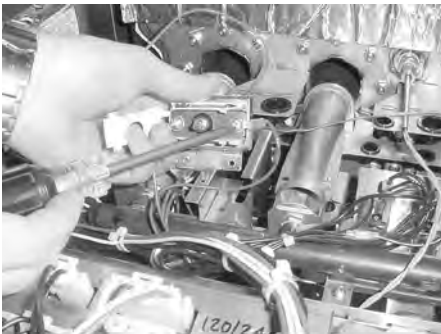

Figure 2-5

- Remove the two screws securing the high limit to the bracket and remove the high limit from bracket.
- Remove the two electrical wires from the high temperature limit control. Figure 2-5.
- Manually reset the control, then check for continuity between the two terminals after resetting the control. If the circuit is open, replace the control, then continue with this procedure. (If the circuit is closed, the high limit is not defective. Re-connect the two electrical wires.)

**2-3. HIGH TEMPERATURE
LIMIT CONTROL
(Gas Units) (Continued)**

Replacement

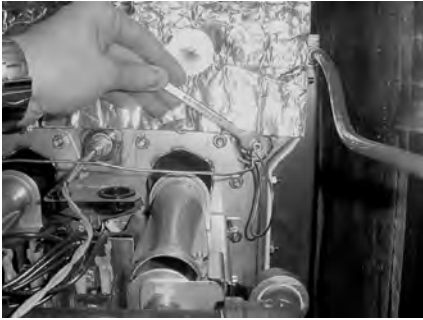

Figure 2-6



Figure 2-7

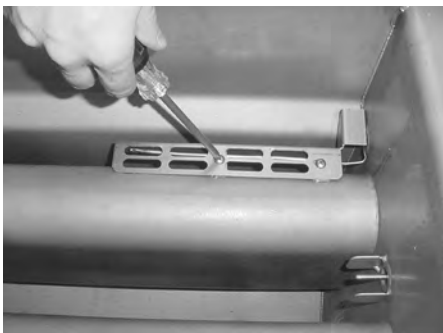

Figure 2-8



To avoid electrical shock or property damage, move the power switch to OFF and disconnect main circuit breaker, or unplug cord at wall receptacle.

1. If the tube is broken or cracked, the control opens, shutting off electrical power to the heat circuit. The control cannot be reset, and it continuously clicks when pushed.
2. Drain the shortening from the frypot and discard. A substance from the tube could contaminate the shortening.
3. Remove the control panel.
4. Using a 5/16” wrench, loosen small inside screw nut on capillary tube. Figure 2-6.
5. Using a 11/16” crows-foot, remove the larger nut securing the capillary tube to the pot. Figure 2-7.
6. Remove the two screws securing the high limit guard and remove guard. Figure 2-8
7. Straighten the capillary tube inside the frypot, and pull the capillary tube through the frypot, from behind the control panel. Remove the defective high limit from the control panel area.
8. Replace new high limit in reverse order.



To avoid electrical shock or other injury, run the capillary line under and away from all electrical power wires and terminals. The tube must never be in such a position where it could accidentally touch the electrical power terminals.

2-4. COMPLETE CONTROL PANEL REPLACEMENT

Should the control board become inoperative, follow these instructions for replacing the board.



Figure 2-9

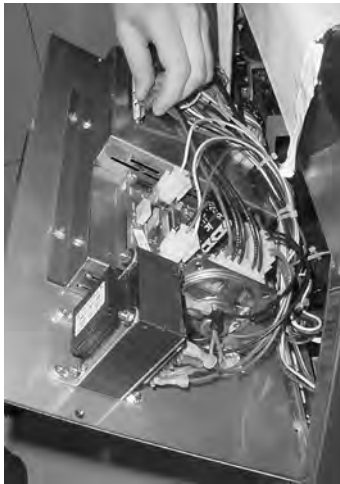

Figure 2-10

1. Remove electrical power supplied to the unit.



To avoid electrical shock or property damage, move the power switch to OFF and disconnect main circuit breaker, or unplug cord at wall receptacle.

2. Remove the two screws securing the control panel and lift out. Figure 2-9.
3. Unplug the wire connectors going to the control panel. Figure 2-10.
4. Remove transformer(s) from control panel. They must be installed on the replacement panels.
5. Install new control panel in reverse order.



When plugging connectors onto new control panel, be sure the connectors are inserted onto all of the pins, and that the connectors are not forced onto the pins backwards. If not connected properly, damage to the board could result.

2-5. POWER SWITCH



Figure 2-11

1. Remove electrical power supplied to fryer.



To avoid electrical shock or property damage, move the power switch to OFF and disconnect main circuit breaker, or unplug cord at wall receptacle.

2. Remove control panel.
3. Label and remove wires from the switch. With test instrument check across the terminals of the switch with switch in the on position, and the circuit should be closed. In the off position, the circuit should be open. If the switch checks defective, replace by continuing with this procedure. Figure 2-11.

2-5. POWER SWITCH (Continued)



Figure 2-12

4. With control panel removed, and the wires off the switch, push in on tabs on the switch to remove from panel. Figure 2-12.
5. Replace with new switch, and reconnect wires to switch.
6. Replace the control panel.

2-6. TEMPERATURE PROBE REPLACEMENT (Gas)

The temperature probe relays the actual shortening temperature to the control board. If it becomes disabled, “E06” shows in the display. Also, if the shortening temperature is out of calibration more than 10°F or C°, the probe should be replaced. An Ohm check can be performed also. See chart below.

Temp. F	Temp. C	Resistance Ohms	Temp. F	Temp. C	Resistance Ohms
50	10.00	1039.02	250	121.11	1464.79
60	15.56	1060.65	260	126.67	1485.71
70	21.11	1082.24	270	132.22	1506.58
80	26.67	1103.80	280	137.78	1527.43
90	32.22	1125.32	290	143.33	1548.23
100	37.78	1146.81	300	148.89	1569.00
110	43.33	1168.26	310	154.44	1589.73
120	48.89	1189.67	320	160.00	1610.43
130	54.44	1211.05	325	162.78	1620.77
140	60.00	1232.39	330	165.56	1631.09
150	65.56	1253.70	340	171.11	1651.72
160	71.11	1274.97	350	176.67	1672.31
170	76.67	1296.20	360	182.22	1692.86
180	82.22	1317.40	365	185.00	1703.13
185	85.00	1327.99	370	187.78	1713.38
190	87.78	1338.57	380	193.33	1733.87
200	93.33	1359.69	390	198.89	1754.31
210	98.89	1380.79	400	204.44	1774.72
212	100.00	1385.00	410	210.00	1795.10
220	104.44	1401.84	420	215.56	1815.44
230	110.00	1422.86	430	221.11	1835.74
240	115.56	1443.85	440	226.67	1856.01



Figure 2-13

1. Remove electrical power supplied to the fryer.



To avoid electrical shock or property damage, move the power switch to OFF and disconnect main circuit breaker, or unplug cord at wall receptacle.



Figure 2-14

2. Drain the shortening from the frypot.
3. Remove the control panel and heat shield from control area. Figure 2-13.
4. Using a ½ inch wrench, remove the nut on the compression fitting. Figure 2-14.

2-6. TEMPERATURE PROBE REPLACEMENT (GAS)
(Continued)



Figure 2-15

- Remove the probe from the frypot, and disconnect wire connector from the control panel. Figure 2-15.

- Place the nut and new ferrule on the new probe and insert the probe into the compression fitting until it extends one (1) inch (2.54cm) into the frypot. Figure 2-16.

- Tighten hand tight and then a half turn with wrench.



Excess force will damage probe.

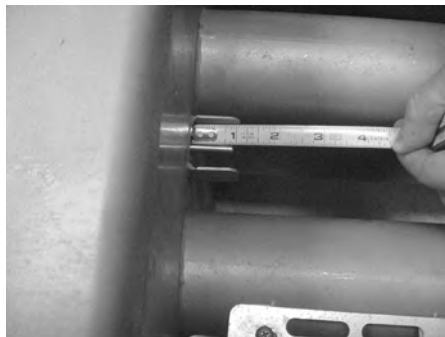

Figure 2-16

- Connect new probe to PC board and replace control panel.

- Replace shortening, and turn power on to check out fryer.

2-7. TEMPERATURE PROBE REPLACEMENT (Gas)
REPLACEMENT (ELECTRIC)

The temperature probe relays the actual shortening temperature to the control board. If it becomes disabled, “E06” shows in the display. Also, if the shortening temperature is out of calibration more than 10°F or C°, the probe should be replaced. An Ohm check can also be performed. See chart on page 2-5.

- Remove electrical power supplied to the fryer.



To avoid electrical shock or property damage, move the power switch to OFF and disconnect main circuit breaker, or unplug cord at wall receptacle.



Figure 2-17

- Drain the shortening from the frypot.

- Remove screws securing rear cover of fryer, and remove rear cover. Figure 2-17.

2-7. TEMPERATURE PROBE REPLACEMENT (ELECTRIC) (Continued)



Figure 2-18

4. Using a ½ inch wrench, remove the nut on the compression fitting. Figure 2-18.
5. Remove the probe from the frypot, and disconnect probe.
6. Place the nut and new ferrule on the new probe and insert the probe into the compression fitting until it extends one (1) inch (2.54cm) into the frypot.
7. Reconnect new probe onto wires, replace rear cover, and fryer is now ready for use.

2-8. FLAME SENSOR/ PILOT / IGNITOR ASSEMBLY (GAS)

The Henny Penny open fryer (gas) has electronic spark ignition that lights a standing pilot. The gap between the spark electrode and the pilot hood should be 1/8 of an inch (3.18 mm). The flame sensor recognizes the pilot flame and allows gas to continue to the pilot. The flame sensor must send a minimum of two (2) micro amps to the ignition module. The pilot flame should be split in two by the flame sensor, causing the flame sensor to be bright red in color.

1. Remove electrical power supplied to the unit.



To avoid electrical shock or property damage, move the power switch to OFF and disconnect main circuit breaker, or unplug cord at wall receptacle.



TO AVOID PERSONAL INJURY OR PROPERTY DAMAGE, BEFORE STARTING THIS PROCEDURE, MOVE THE MAIN POWER SWITCH TO THE OFF POSITION. DISCONNECT THE MAIN CIRCUIT BREAKERS AT THE CIRCUIT BREAKER BOX OR UNPLUG SERVICE CORD FROM WALL RECEPTACLE. TURN OFF THE MAIN GAS SUPPLY TO THE FRYER AND DISCONNECT AND CAP THE MAIN SUPPLY LINE TO FRYER, OR POSSIBLE EXPLOSION COULD RESULT.

**2-8. FLAME SENSOR/
PILOT / IGNITOR
ASSEMBLY (Gas)
(Continued)**

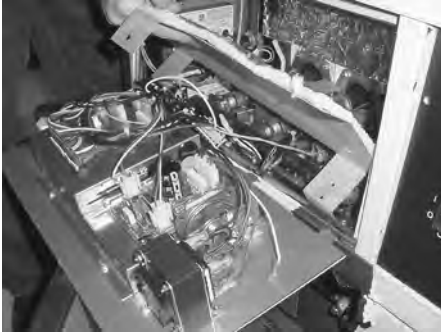

Figure 2-19

2. Remove the control panel and heat shield from control area. Figure 2-19.

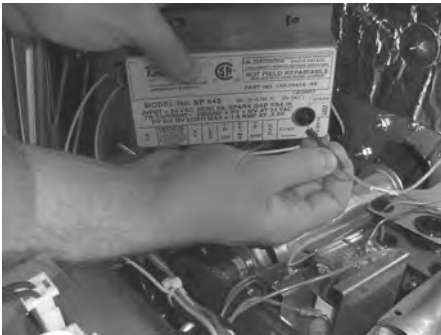

Figure 2-20

3. Disconnect the flame sense wire from ignition module. Figure 2-20.

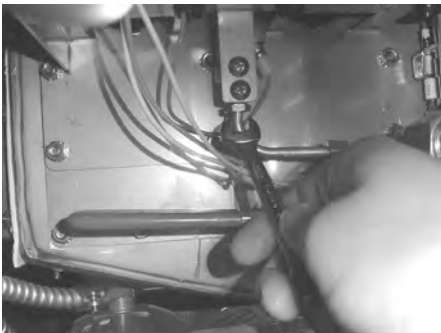

Figure 2-21

4. Using a 7/16" wrench, loosen the nut on the pilot tube and pull tube from assembly. Figure 2-21.

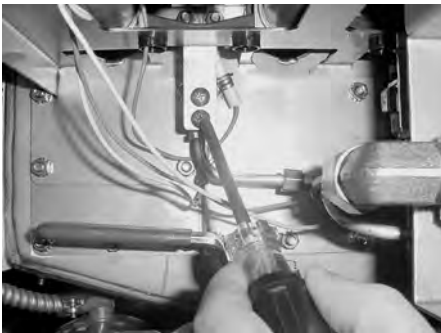

Figure 2-22

5. Remove the two screws securing the assembly and pull assembly from unit. Figure 2-22.
6. Now the flame sensor or or pilot assembly can be removed from bracket.

2-9. IGNITION MODULE

During normal operation, the ignition modules send 24 volts to the ignitors and gas valve. If a module does not sense a pilot flame, the module starts the ignition process again. But, if a pilot light goes out for longer than 10 seconds, or it goes out 3 times within 10 seconds, the module keeps the 24 volts from reaching the gas valve. The burners shut down.

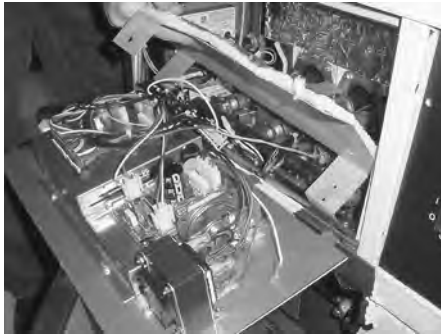

Figure 2-23



Figure 2-24



Figure 2-25

1. Remove electrical power supplied to the unit.



To avoid electrical shock or property damage, move the power switch to OFF and disconnect main circuit breaker, or unplug cord at wall receptacle.

2. Remove the control panel and heat shield from control area. Figure 2-23.
3. Using a 3/8 inch socket, remove the two nuts securing the module. Figure 2-24.
4. Label and remove the wires at module. Figure 2-25.
5. Install new module in reverse order.

2-10. TRANSFORMER REPLACEMENT

The transformer reduces voltage down (to 24V) to accommodate those components with low voltage.

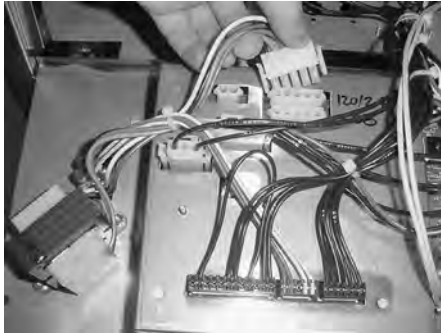

Figure 2-26

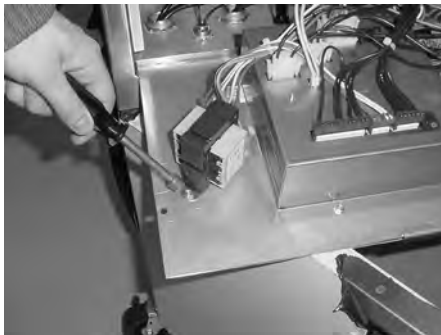

Figure 2-27

1. Remove electrical power supplied to the unit.



To avoid electrical shock or property damage, move the power switch to OFF and disconnect main circuit breaker, or unplug cord at wall receptacle.

2. Remove the control panel
3. Remove the two wire connectors to disconnect transformer From panel. Figure 2-26.
4. Using a 3/8” nut-driver, remove the two nuts securing the transformer to the panel and remove transformer. Figure 2-27.
5. Install the new transformer in reverse order.

2-11. CONTROL & I/O BOARDS REPLACEMENT

I/O Power Supply Control

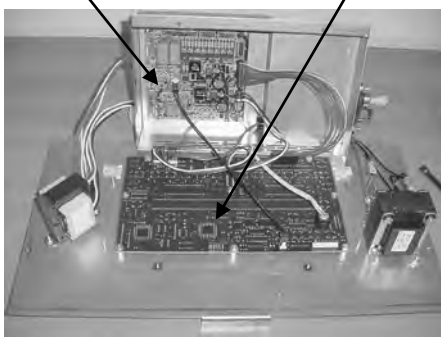

Figure 2-28

1. Remove electrical power supplied to the unit.



To avoid electrical shock or property damage, move the power switch to OFF and disconnect main circuit breaker, or unplug cord at wall receptacle.

2. Remove the control.
3. Using a 5/16” nut-driver or wrench, remove the 4 nuts securing the PC shield and remove shield. Figure 2-28.
4. Disconnect the wire assemblies from the appropriate board.
5. Using a 5/16” nut-driver or wrench, remove the 4 nuts securing the appropriate board to the shroud.
6. Install the new board in reverse order.

2-12. VACUUM SWITCH REPLACEMENT

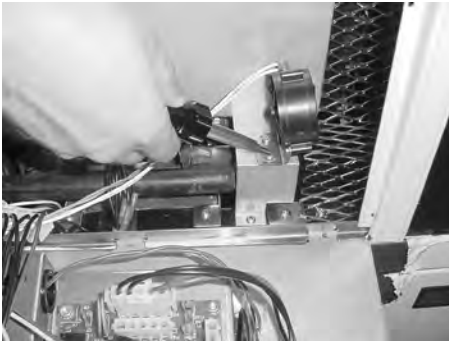

Figure 2-29

This switch senses the airflow from the induction blower. If the airflow is reduced below a set amount, the switch opens and the I/O board cuts power to the gas control valve, which shuts the pilot flame off.

1. Remove electrical power supplied to the unit.



To avoid electrical shock or property damage, move the power switch to OFF and disconnect main circuit breaker, or unplug cord at wall receptacle.



Figure 2-30

2. Remove the control panel.

3. Remove the 2 screws securing the switch to the heat shield. Figure 2-29.

4. Remove the air hose from the air switch. Figure 2-30.

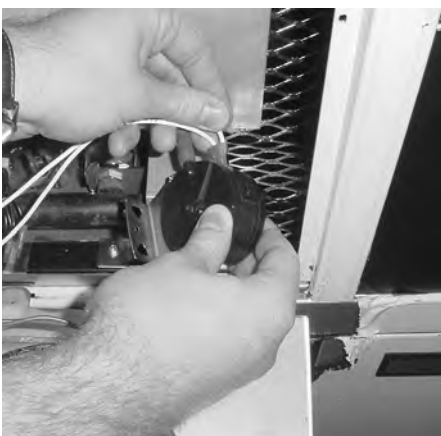

Figure 2-31

5. Label and remove wires from air switch. Figure 2-31.

6. Install new vacuum switch in reverse order.



To avoid property damage, do not tamper with, or disassemble this component. It is set and sealed from the factory and is not to be adjusted.

2-13. DRAIN MICROSWITCH REPLACEMENT

Upon turning the drain handle, the drain microswitch should “open”, cutting off the pilot flame. This will prevent the fryer from heating while shortening is being drained from the frypot.

1. Remove electrical power supplied to the unit.



To avoid electrical shock or property damage, move the power switch to OFF and disconnect main circuit breaker, or unplug cord at wall receptacle.

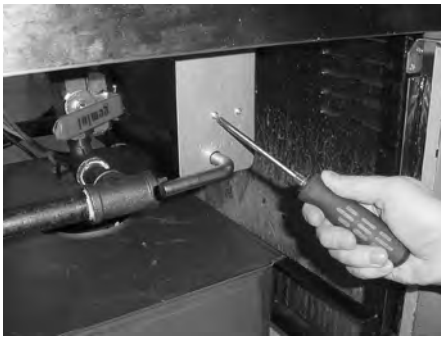

Figure 2-32

2. The following check should be made to determine if the drain microswitch is defective.
 - a. Remove the two screws and nuts securing the microswitch to the drain rod valve bracket, and remove microswitch. Figure 2-32.



Figure 2-33

- b. Remove wires from the switch. Figure 2-33.
- c. Check for continuity across the two outside terminals of the drain switch. If the circuit is open, the drain switch is defective. The circuit opens by pressing on the actuator of the microswitch.

3. If defective, replace switch in reverse order.

2-14. FILTER SWITCH REPLACEMENT



Figure 2-34

1. Remove electrical power supplied to the unit.



To avoid electrical shock or property damage, move the power switch to OFF and disconnect main circuit breaker, or unplug cord at wall receptacle.

2. Open the door (left door on 2 well units), and remove the 2 screws securing the switch box cover. Figure 2-34.

**2-14. FILTER SWITCH
REPLACEMENT**
(Continued)



Figure 2-35



Figure 2-36

**2-15. GAS CONTROL VALVE
REPLACEMENT**

3. Label and remove the wires from the switch. With test instrument check across the terminals of the switch. With the switch in the on position, the circuit should be closed. With the switch in the off position, the circuit should be open. If the switch is defective, replace by continuing with this procedure. Figure 2-35.

4. With wires removed from the switch, push in on tabs on the switch and remove switch from front of switch box cover. Figure 2-36.

5. Push new switch into panel and reconnect wires.

The gas valve assembly controls the flow of gas to the pilot and the main burner. The valve has two 24-volt coils, which are regulated by the P and M terminals on the valve. The C terminal is the common terminal. For gas flow to the pilot, 24 VAC must be present between the P and C terminals. For gas flow to the main burner, 24 VAC must be present between the M and C terminals.



TO AVOID PERSONAL INJURY OR PROPERTY DAMAGE, BEFORE STARTING THIS PROCEDURE, MOVE THE MAIN POWER SWITCH TO THE OFF POSITION. DISCONNECT THE MAIN CIRCUIT BREAKERS AT THE CIRCUIT BREAKER BOX OR UNPLUG SERVICE CORD FROM WALL RECEPTACLE. TURN OFF THE MAIN GAS SUPPLY TO THE FRYER AND DISCONNECT AND CAP THE MAIN SUPPLY LINE TO FRYER, OR POSSIBLE EXPLOSION COULD RESULT.

**2-15. GAS CONTROL VALVE
REPLACEMENT
(Continued)**



Figure 2-37

1. Remove right side panel. Figure 2-37.

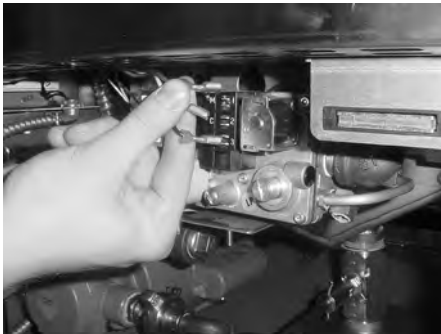

Figure 2-38

2. Label and remove wires from gas valve. Figure 2-38



Figure 2-39

3. Using a 7/16 wrench, remove the pilot line from the gas valve. Figure 2-39.



Figure 2-40

4. Using a 1-inch wrench, loosen the nut securing the main gas inlet line to the gas valve. Figure 2-40.

**2-15. GAS CONTROL VALVE
REPLACEMENT**
(Continued)



Figure 2-41

5. Using a pipe wrench, loosen the outlet fitting to the burner.
Figure 2-41.

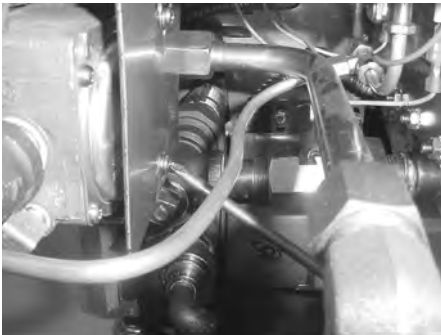

Figure 2-42

6. Using a Phillips screwdriver, remove the 2 screws securing the gas valve to the bracket and remove gas valve from unit.
Figure 2-42.

7. Remove the fittings from the gas valve and install in new gas valve.

8. Install the new gas valve in reverse order.

**2-16. BLOWER MOTOR
REPLACEMENT**

The blower motor assembly induces the draft for the burners. If the blower motor fails, the air switch will fail to close, causing an “E-20B” error code in the display.

1. Remove electrical power supplied to the unit.



To avoid electrical shock or property damage, move the power switch to OFF and disconnect main circuit breaker, or unplug cord at wall receptacle.



Figure 2-43

2. Remove screws securing the rear cover to the unit.
Figure 2-43.

**2-16. BLOWER MOTOR
REPLACEMENT
(Continued)**



Figure 2-44

3. Remove the wire cover from the blower motor housing. Figure 2-44.



Figure 2-45

4. Remove wire nuts connecting blower motor wires to wires in conduit. Figure 2-45.



Figure 2-46

5. Loosen conduit from blower motor. Figure 2-46.



Figure 2-47

7. Remove screws connecting flue to blower. Figure 2-47.

**2-16. BLOWER MOTOR
REPLACEMENT
(Continued)**



Figure 2-48

8. Using 3/8 inch nut driver, remove nuts securing blower to the unit. Figure 2-48. Pull blower from unit.

9. Install new blower in reverse order.

**2-17. HEATING ELEMENTS
(ELECTRIC)**

NOTICE

Heating elements are available for 208 and 230 voltage. Check data plate to determine correct voltage.

Checkout

If the shortening temperature recovery is very slow or at a slower rate than required, this may indicate defective heating element(s). An ohmmeter quickly indicates if the elements are shorted or open.



Figure 2-49

1. Remove electrical power supplied to the frypot to be checked



To avoid electrical shock or property damage, move the power switch to OFF and disconnect main circuit breaker, or unplug cord at wall receptacle, to the frypot to be worked on. Be aware the other control on 2-frypot units will have power.

2. Remove rear cover. Figure 2-49.
3. Using a flat-head screwdriver, remove the appropriate wires from the terminal blocks. Figure 2-50.

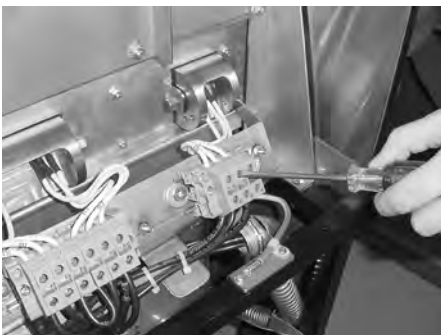

Figure 2-50

2-17. HEATING ELEMENTS
(ELECTRIC)
(Continued)

4. Perform an ohm check on one element at a time, with wires disconnected. The 2 elements actually have 3 small heating elements inside the outer plate. It's important to check between the correct wires to obtain an accurate ohm reading. The wires are labeled for your convenience. If the resistance is not within tolerance, replace the element.

Wire Nos.	Voltage	Wattage	Ohms (cold)
1L1 to 1L1	208	11000	11.7
1L2 to 1L2	208	11000	11.7
1L3 to 1L3	208	11000	11.7
1L1 to 1L1	240	11000	15.7
1L2 to 1L2	240	11000	15.7
1L3 to 1L3	240	11000	15.7

Replacement



Figure 2-51

1. Drain the shortening from the frypot
2. Remove the high limit bulb holder from the heating element inside the frypot. See High Limit Temperature Control-Electric Section.
3. Using a Phillip's-head screwdriver, remove the screws securing the element to the element hinges. Figure 2-51.
4. Pull element from fryer and replace with new element, following steps in reverse order.
5. Connect the power cord to the wall receptacle or close wall circuit breaker.

CAUTION

Heating elements should never be energized without shortening in the frypot, or damage to the elements could result.

6. Replace the shortening in the frypot, and unit is ready for operation.

2-18. HEATING CONTACTORS (ELECTRIC)

Each well of an electric fryer requires two switching contactors. The first in line is the primary contactor and the second in line is the heat contactor. When open, the primary contactor does not allow power to flow to the heat contactor. When closed, the primary supplies voltage to the heat contactor. When the heat contactor is open, no voltage is supplied to the heating elements. When the heat contactor closes, voltage is supplied to the heating elements.

Checkout (Power Removed) 1. Remove electrical power supplied to frypot to be worked on.



To avoid electrical shock or property damage, move the power switch to OFF and disconnect main circuit breaker, or unplug cord at wall receptacle, to the frypot to be worked on. Be aware the other control on 2-frypot units will have power.

Heat Contactor (Mercury)

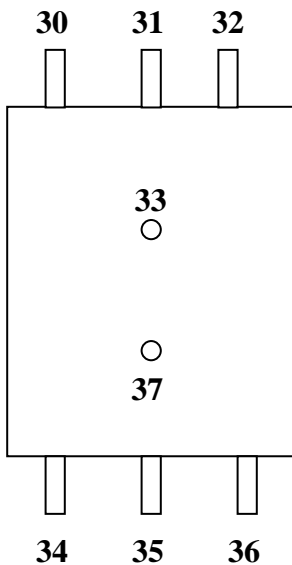

Figure 2-52

2. Remove the control panel.
3. Perform a check on the contactor as follows:

Test Points

Results

From 23 to 29	open circuit
From 24 to 28	open circuit
From 25 to 27	open circuit
From 30 to 34	open circuit
From 31 to 35	open circuit
From 32 to 36	open circuit
From 33 to 37	ohm reading 1700
From 22 to 26	ohm reading 415

Primary Contactor

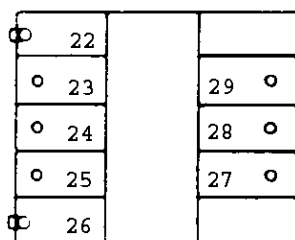

Figure 2-53



Wires should be removed and labeled to obtain an accurate check of contactors.

2-18. HEATING CONTACTORS (ELECTRIC) (Continued)



To avoid electrical shock, make connections before applying power, take reading, and remove power before removing meter leads. The following checks are performed with the wall circuit breaker closed and the main power switch in the ON position.

1. Re-apply power to unit and turn power switch to ON.
2. Using illustrations from previous page, check voltage as follows:

<u>Test Points</u>	<u>Results</u>
<u>Heat Contactor</u>	
From terminal 34 to 35	The voltage should read the same at each terminal
From terminal 35 to 36	
From terminal 34 to 36	

<u>Test Points</u>	<u>Results</u>
<u>Primary Contactor</u>	
From terminal 27 to 28	It should correspond to the voltage stated on the data plate.
From terminal 28 to 29	
From terminal 27 to 29	

Replacement (Heat Contactor)

If neither contactor is defective it must be replaced as follows:



To avoid electrical shock or property damage, move the power switch to OFF and disconnect main circuit breaker, or unplug cord at wall receptacle, to the frypot to be worked on. Be aware the other control on 2-frypot units will have power.

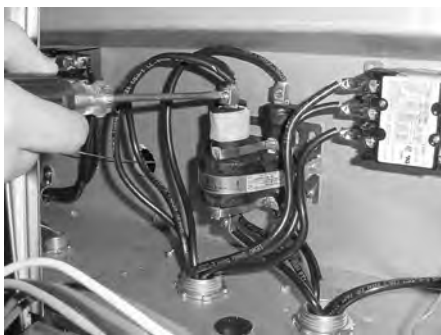

Figure 2-54

1. Remove only the wires directly connected to the contactor being replaced. Label the wires for replacement. Figure 2-54.

2-18. HEATING
CONTACTORS
(ELECTRIC)
Continued)



Figure 2-55

2. Remove the screws securing the contactor to the shroud, and remove contactor. Figure 2-55.
3. Install new contactor, and see steps 4 and 5.

Replacement
(Primary Contactor)

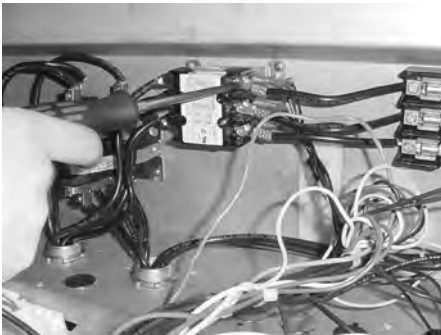

Figure 2-56

1. Remove only the wires directly connected to the contactor being replaced. Label the wires for replacement. Figure 2-56.
2. Remove screws securing contactor to unit and remove contactor. Figure 2-57.



Figure 2-57

3. Install new contactor.
4. Reinstall the control panel.
5. Reconnect power to the fryer and test for proper operation.

2-19. SPEAKER ASSEMBLY

The speaker assembly emits audible signals to let the operator know when cooking and hold times are finished.

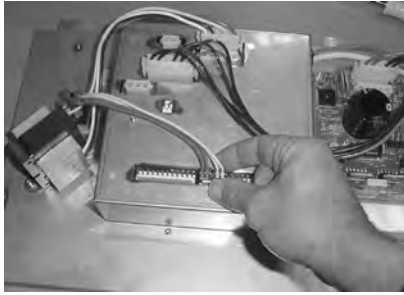

Figure 2-58

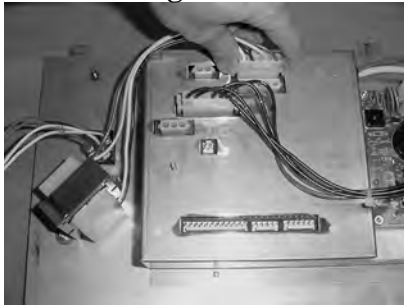

Figure 2-59



Figure 2-60

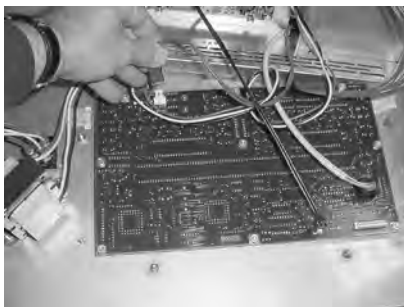

Figure 2-61



Figure 2-62

1. Remove electrical power supplied to unit.



To avoid electrical shock or property damage, move the power switch to OFF and disconnect main circuit breaker, or unplug cord at wall receptacle.

2. Remove control panel.
3. Pull the power switch connector from back of panel. Figure 2-58.
4. Pull the transformer connectors from back of panel. Figure 2-59.
5. Using a 5/16" nutdriver or wrench, remove the 4 nuts securing the PC board shield and pull shield from studs. Figure 2-60.
6. Pull the speaker connector from control board. Figure 2-61.
7. Using a 5/16" nut-driver or wrench, remove the 2 nuts securing the speaker to the shield and remove speaker from panel. Figure 2-62.
8. Install new speaker in reverse order.

**2-20. HIGH TEMPERATURE
LIMIT CONTROL
(ELECTRIC)**



Figure 2-63

This high temperature control is a safety, manual reset control, which senses the temperature of the shortening. If the shortening temperature exceeds 425°F (218°C), this switch opens and shuts off heat to the frypot, and E10 shows in control display. When the temperature of the shortening drops to a safe operation reset the high limit by pressing the reset button. The reset button is located behind the frypot, in the element hinge. A small instrument, such as a Phillip's head screwdriver, or Allen wrench must be used to reset the high limit. This allows heat to be supplied to the frypot once again. See Figure 2-63.

Before replacing a high temperature limit control, check to see that its circuit is closed.

NOTICE

The shortening temperature must be below 380°F (193°C) to accurately perform this check.

1. Remove electrical power supplied to fryer.



To avoid electrical shock or property damage, move the power switch to OFF and disconnect main circuit breaker, or unplug cord at wall receptacle.

Checkout



Figure 2-64

2. Remove rear cover of fryer. Figure 2-64.



Figure 2-65

3. Remove the two screws securing the high limit to the bracket and pull high limit from bracket. Figure 2-65.

**2-20. HIGH TEMPERATURE
LIMIT CONTROL
(ELECTRIC)
(Continued)**



Figure 2-66

4. Pull back cardboard cover and remove the two electrical wires from the high temperature limit control. Figure 2-66.

5. Manually reset the control, then check for continuity between the two terminals after resetting the control. If the circuit is open, replace the control, then continue with this procedure. (If the circuit is closed, the high limit is not defective. Reconnect the two electrical wires.)

Replacement



To avoid electrical shock or property damage, move the power switch to OFF and disconnect main circuit breaker, or unplug cord at wall receptacle, to the frypot to be worked on. Be aware the other control on 2-frypot units will have power.



Figure 2-67

1. Drain the shortening from the frypot.

2. Remove capillary from brackets on upper part of element. Figure 2-67.



Figure 2-68

3. Remove capillary bulb from bulb holder inside the frypot.

**2-20. HIGH TEMPERATURE
LIMIT CONTROL
(ELECTRIC)
(Continued)**



Figure 2-69

4. Straighten the capillary tube, and pull capillary tube through the hole in the element hinge, from the rear of the fryer.
5. Remove the defective control from the fryer.
6. Straighten the capillary tube on the new high limit, and thread the capillary tube through the hole in the element hinge. Figure 2-69.
7. Reattach the capillary to the brackets on the upper and lower parts of the elements.

CAUTION

DO NOT crimp or kink the capillary tube during installation. Also, keep capillary tube behind element to protect from damage from the basket or during cleaning. Damage to the capillary tube reduces the life of the high limit, or causes the high limit to fail.

8. Connect wires to new high limit body and fasten to bracket, using the two screws removed in the checkout part of this section.

NOTICE

Make sure red reset button of high limit lines up with the plunger that inserts into the element hinge.



To avoid electrical shock or other injury, run the capillary line under and away from all electrical power wires and terminals. The tube must never be in such a position where it could accidentally touch the electrical power terminals

9. Re-install the rear cover and unit is now ready for use.

2-21. FILTER PUMP AND MOTOR REMOVAL



Figure 2-70



Figure 2-71



Figure 2-72



Figure 2-73

1. Remove electrical power supplied to unit.



To avoid electrical shock or property damage, move the power switch to OFF and disconnect main circuit breaker, or unplug cord at wall receptacle.

2. Open the door (left door on 2 well units), and remove the 2 screws securing the switch box cover and pull filter motor wires from filter switch. Figure 2-70.

3. Remove the 2 screws securing the switch box to the frame. Figure 2-71

4. Loosen screws on conduit connector and pull conduit from the connector. Figure 2-72.

5. Disconnect filter union to filter in drain pan.

6. Using a pipe wrench, disconnect the outlet pipe to frypot. Figure 2-73.

**2-21. FILTER PUMP AND
MOTOR REMOVAL
(Continued)**



Figure 2-74

7. Remove left side panel.
8. Using 9/16" socket or wrenches, remove the bolts and nuts securing the motor to the bracket and pull pump, motor, and piping from unit. Figure 2-74.

**2-22. AUTOLIFT
TRANSFORMER
REPLACEMENT
(if applicable)**

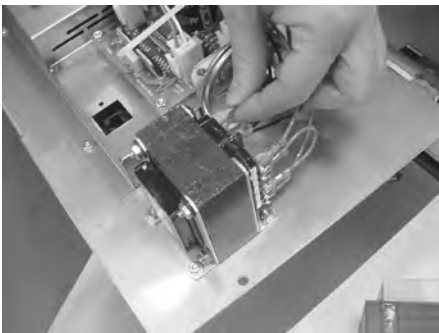

Figure 2-75

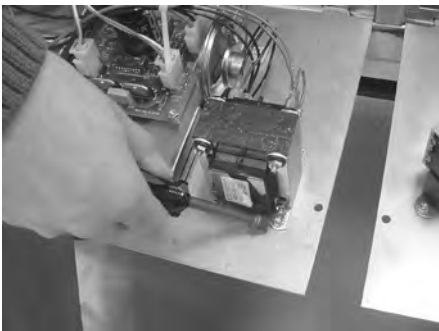

Figure 2-76

1. Remove electrical power supplied to unit.



To avoid electrical shock or property damage, move the power switch to OFF and disconnect main circuit breaker, or unplug cord at wall receptacle.

2. Remove control panel.
3. Label and remove wires from transformer. Figure 2-75.
4. Using 3/8" nut-driver or wrench, remove nuts securing transformer to panel and remove transformer from panel. Figure 2-76.
5. Install new transformer in reverse order.

**2-23. AUTOLIFT PC BOARD
REPLACEMENT
(if applicable)**

Autolift PC Board



Figure 2-77

1. Remove electrical power supplied to unit.



To avoid electrical shock or property damage, move the power switch to OFF and disconnect main circuit breaker, or unplug cord at wall receptacle.

2. Remove control panel
3. Disconnect connectors from PC board.
4. Using 5/16" nut-driver or wrench, remove the 4 nuts securing the autolift PC board to the panel and remove PC board from panel.
5. Install new panel in reverse order.

**2-24. AUTOLIFT
ACTUATOR (MOTOR)
REPLACEMENT
(if applicable)**



Figure 2-78

1. Remove electrical power supplied to unit.



To avoid electrical shock or property damage, move the power switch to OFF and disconnect main circuit breaker, or unplug cord at wall receptacle.

2. Drain shortening from frypot.
3. Remove basket and knock pin from basket hanger. Figure 2-78.
4. Remove rear cover. Figure 2-79.



Figure 2-79

**2-24. AUTOLIFT
ACTUATOR (MOTOR)
REPLACEMENT
(if applicable)**



Figure 2-80

5. Disconnect actuator connector. Figure 2-80.



Figure 2-81

6. Remove female connector from plate. Figure 2-81.



Figure 2-82

7. Using 7/16" socket, remove the 4 nuts securing the support plate. 2 nuts are behind the insulation. Figures 2-82 & 2-83.



Figure 2-83

**2-24. AUTOLIFT
ACTUATOR (MOTOR)
REPLACEMENT
(if applicable)**



Figure 2-84

8. Remove the 2 top screws securing the support plate and remove the plate from the unit. Figure 2-84.



Figure 2-85

9. Using a 15T torx driver, remove the 2 torx screws from the back shroud, and pull the actuator from the unit. Figure 2-85.

10. Install new actuator in reverse order.

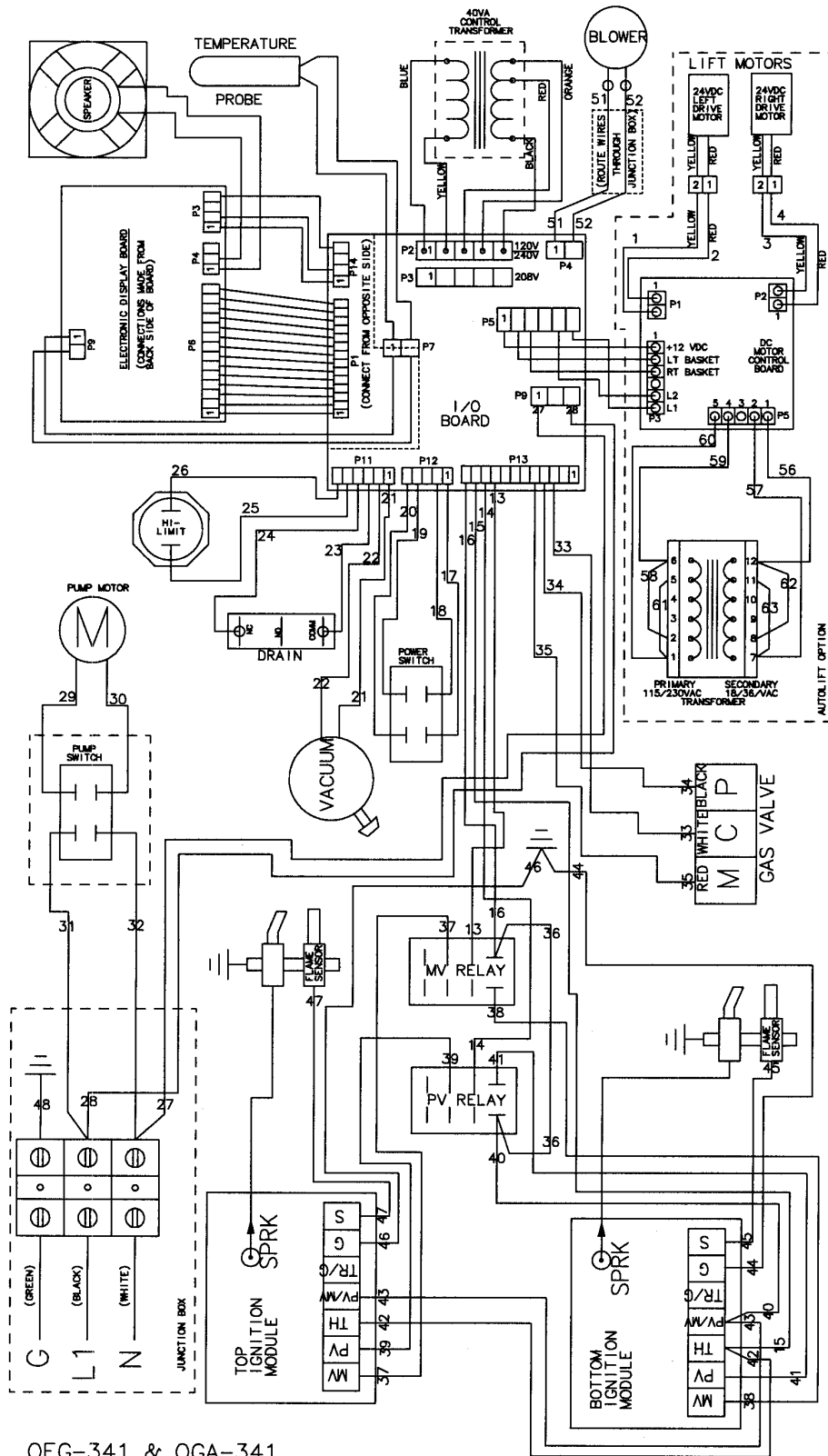

OFG-341 & OGA-341
OPEN FRYER
120V, 60HZ, 2W+G

21840

Drain switch wired N/C

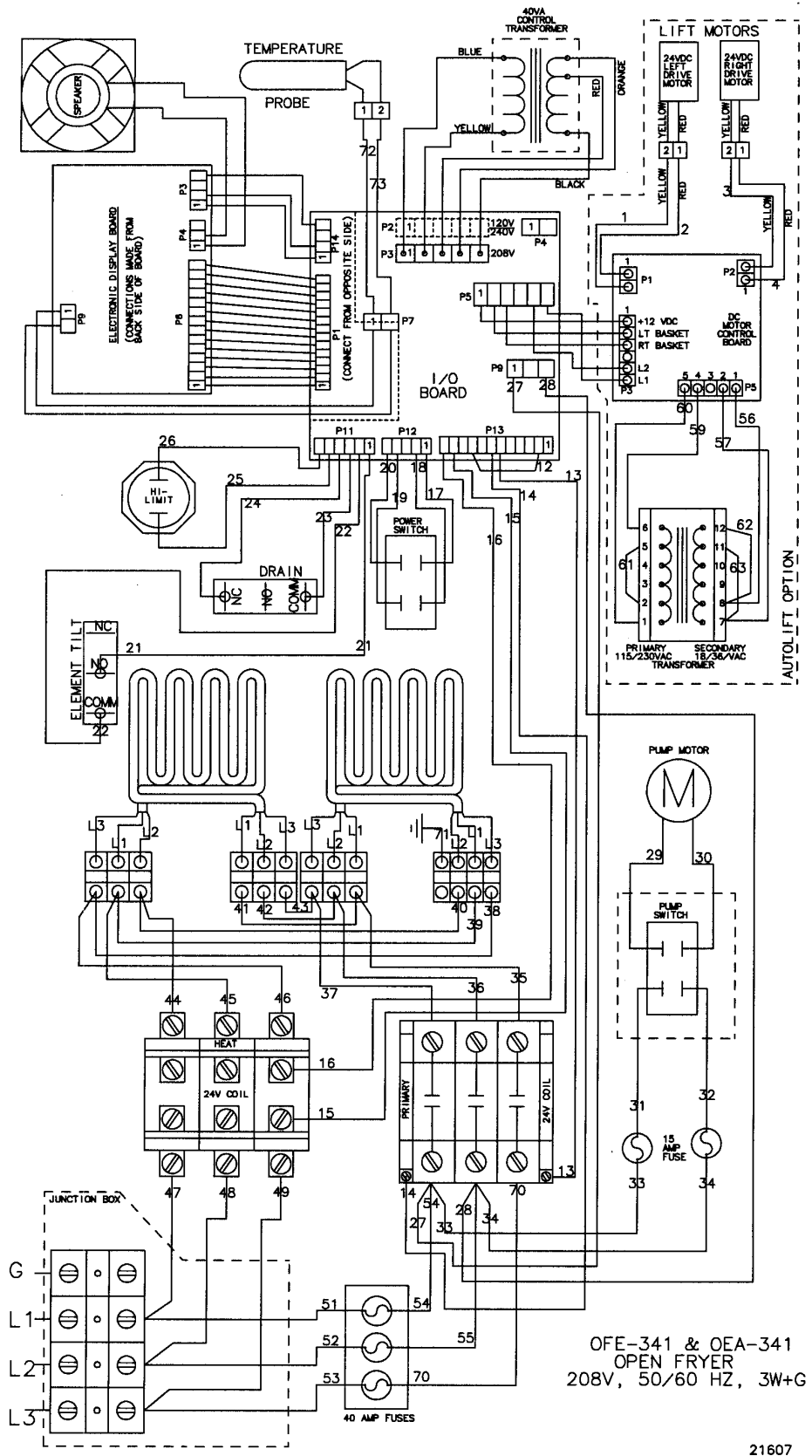

OFE-341 & OEA-341
OPEN FRYER
208V, 50/60 HZ, 3W+G

21607

Drain switch wired N/C

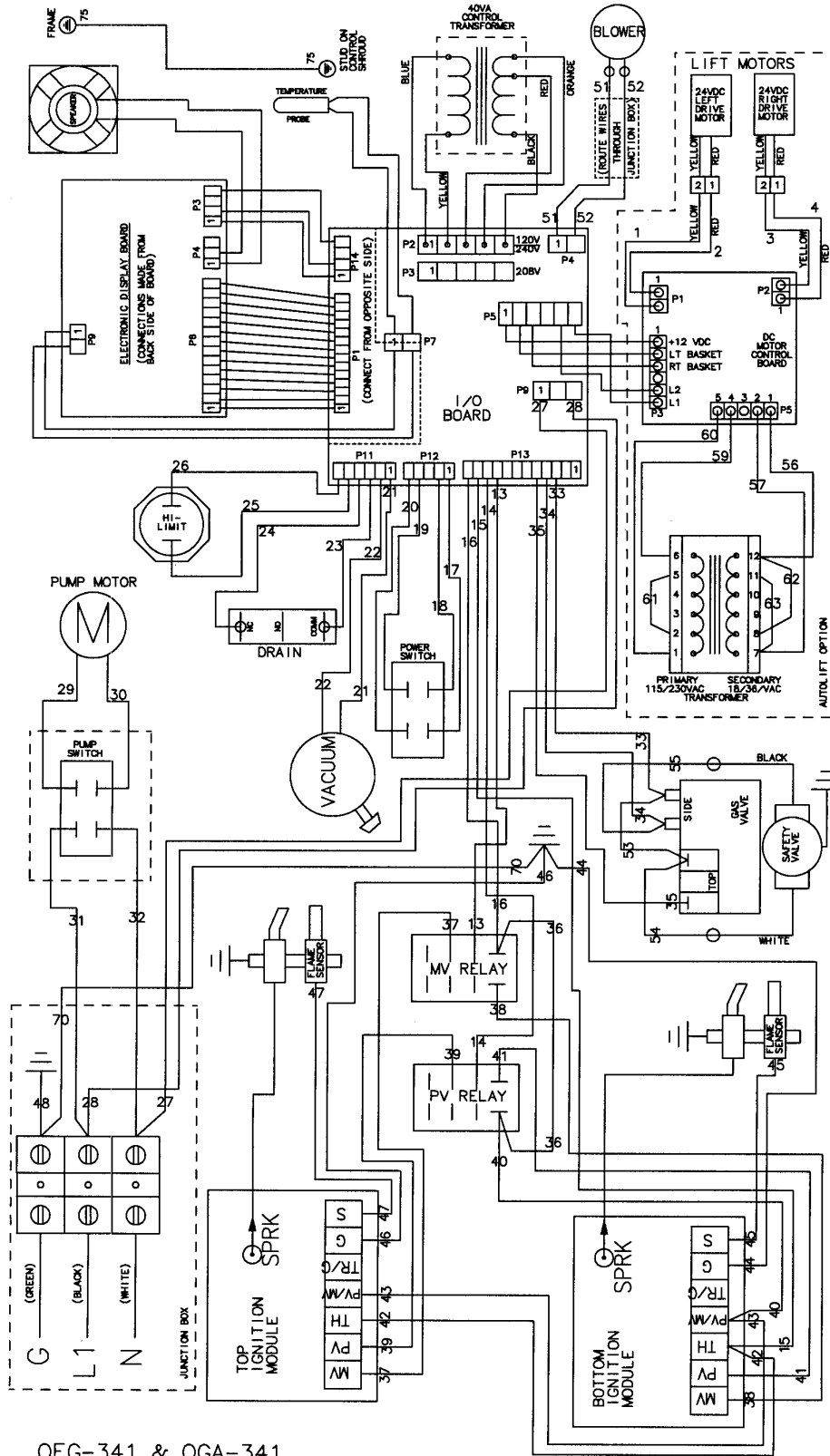

OFG-341 & OGA-341
OPEN FRYER
230V, 50HZ, 1N+G

21659

Drain switch wired N/C

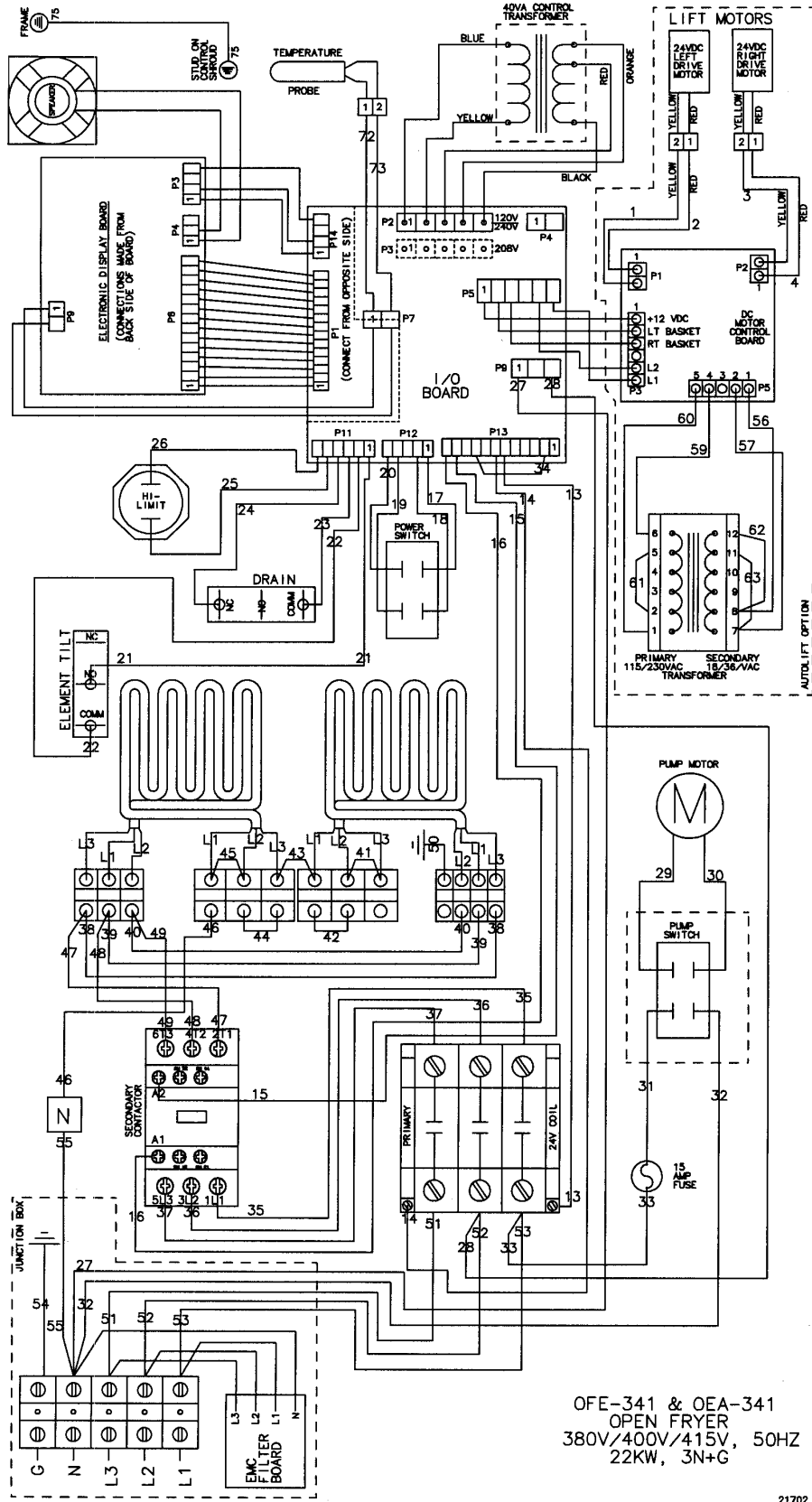

OFE-341 & OEA-341
OPEN FRYER
380V/400V/415V, 50HZ
22KW, 3N+G

21702

Drain switch wired N/C

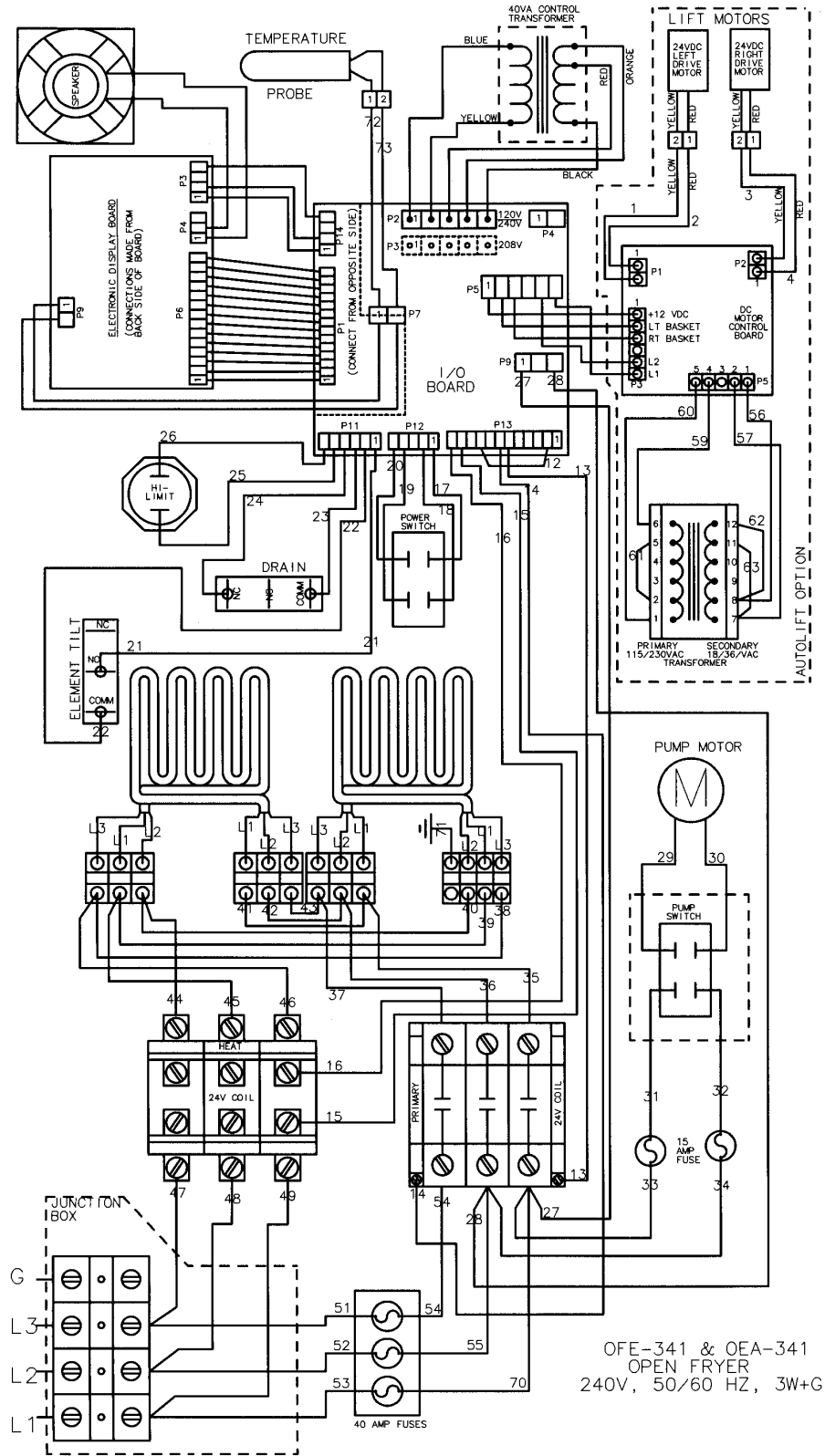

21857

Drain switch wired N/C

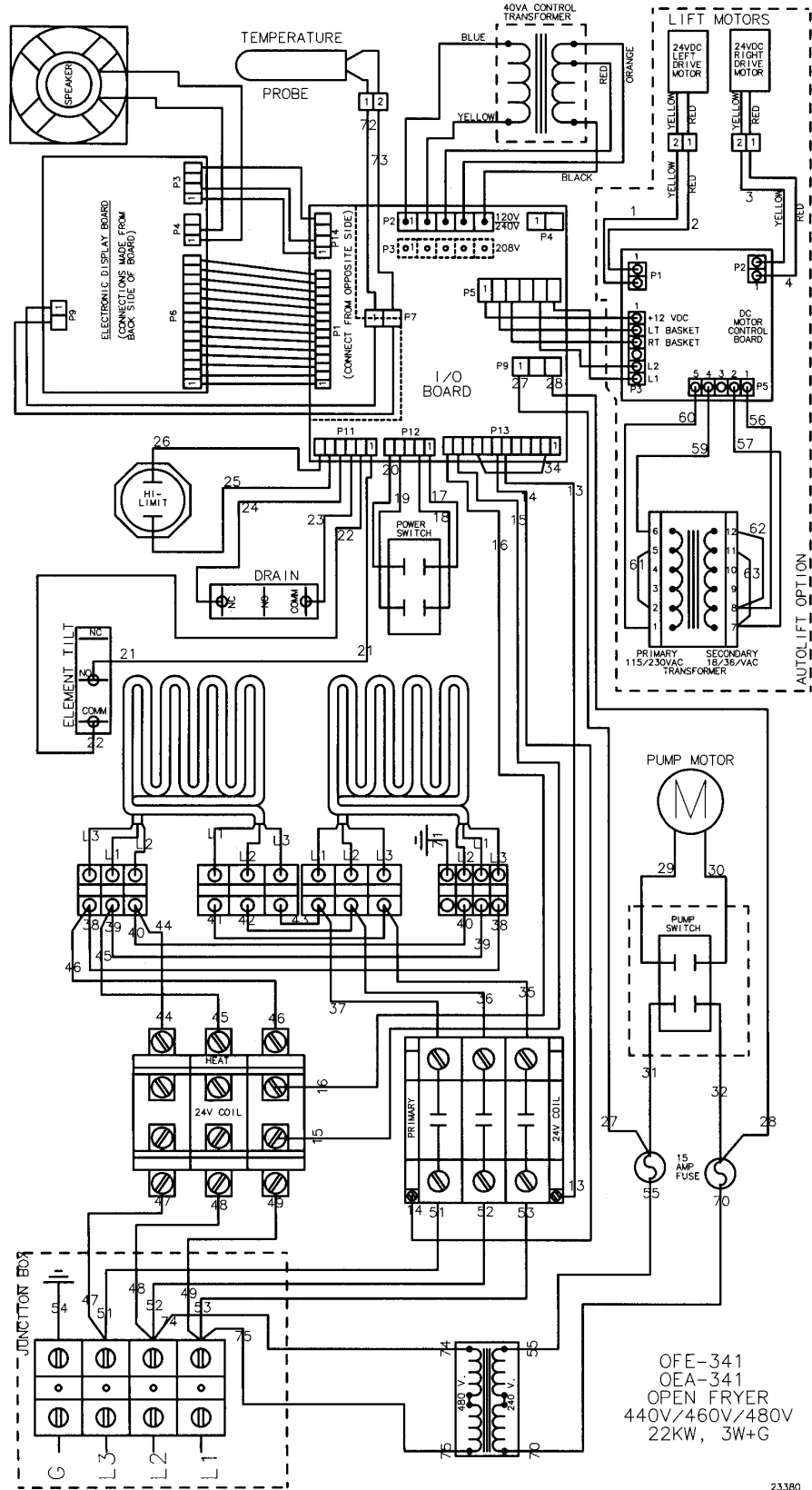

23380

Drain switch wired N/C

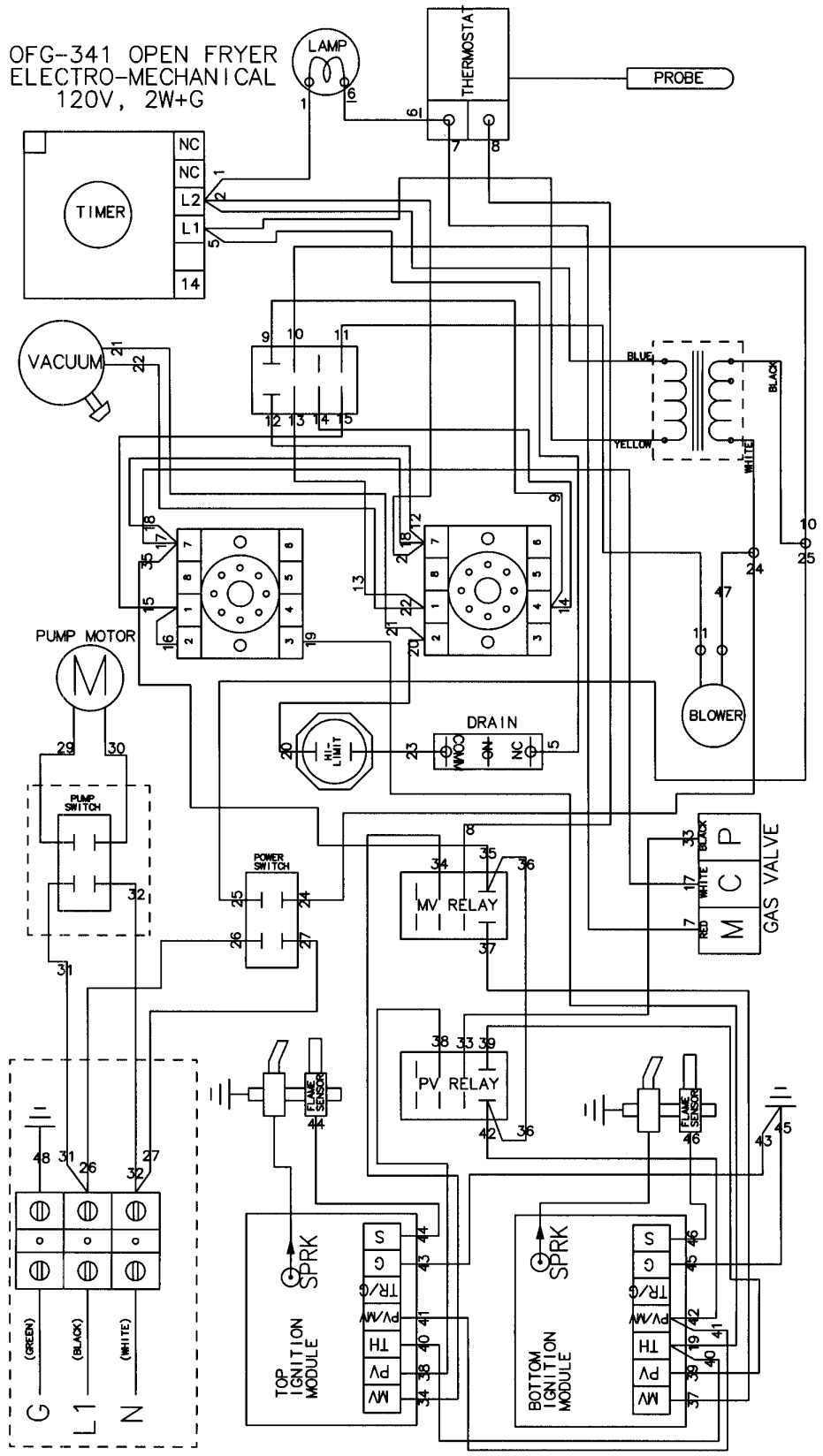

21941

Drain switch wired N/C

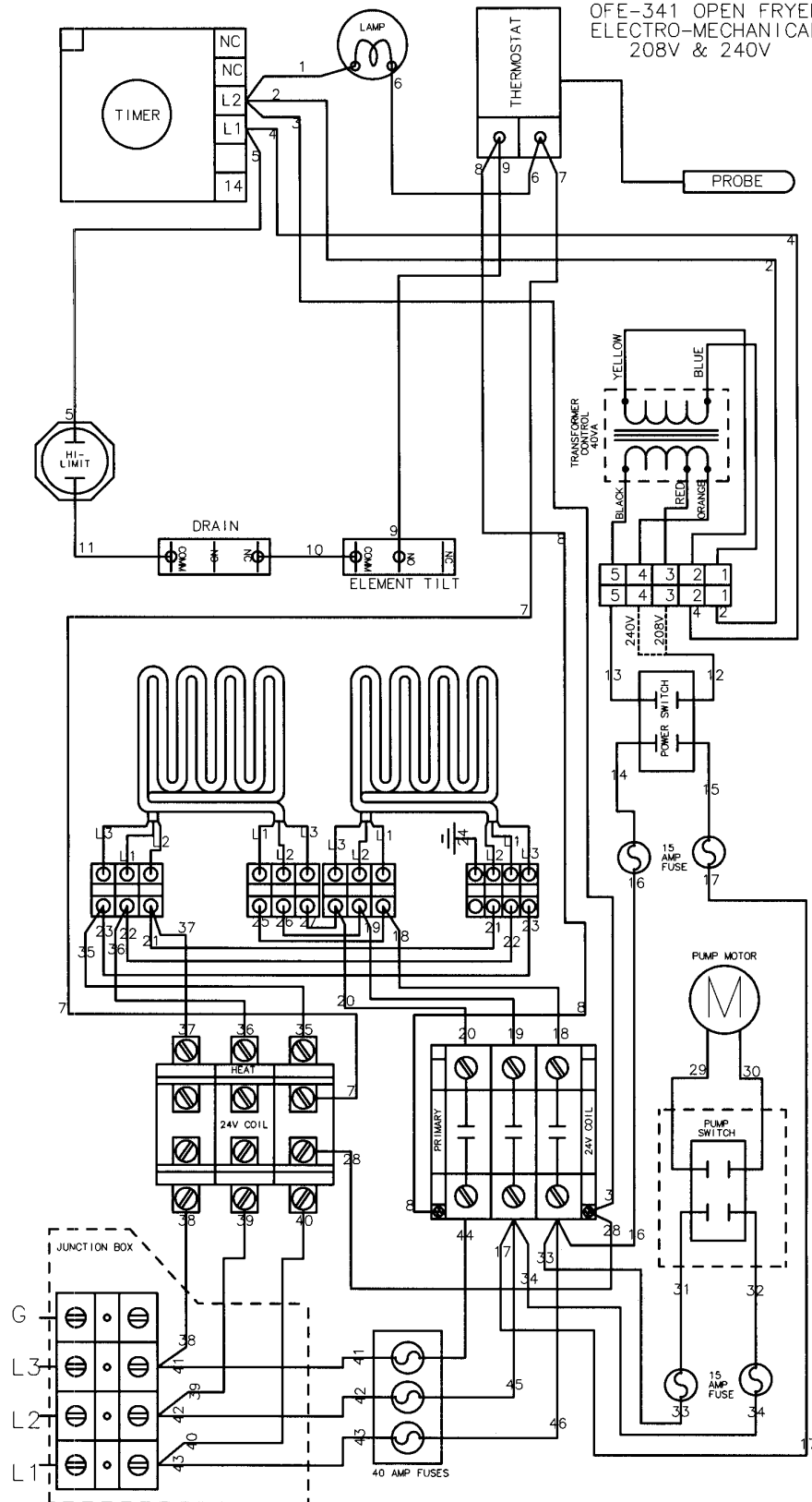

21858

Drain switch wired N/C

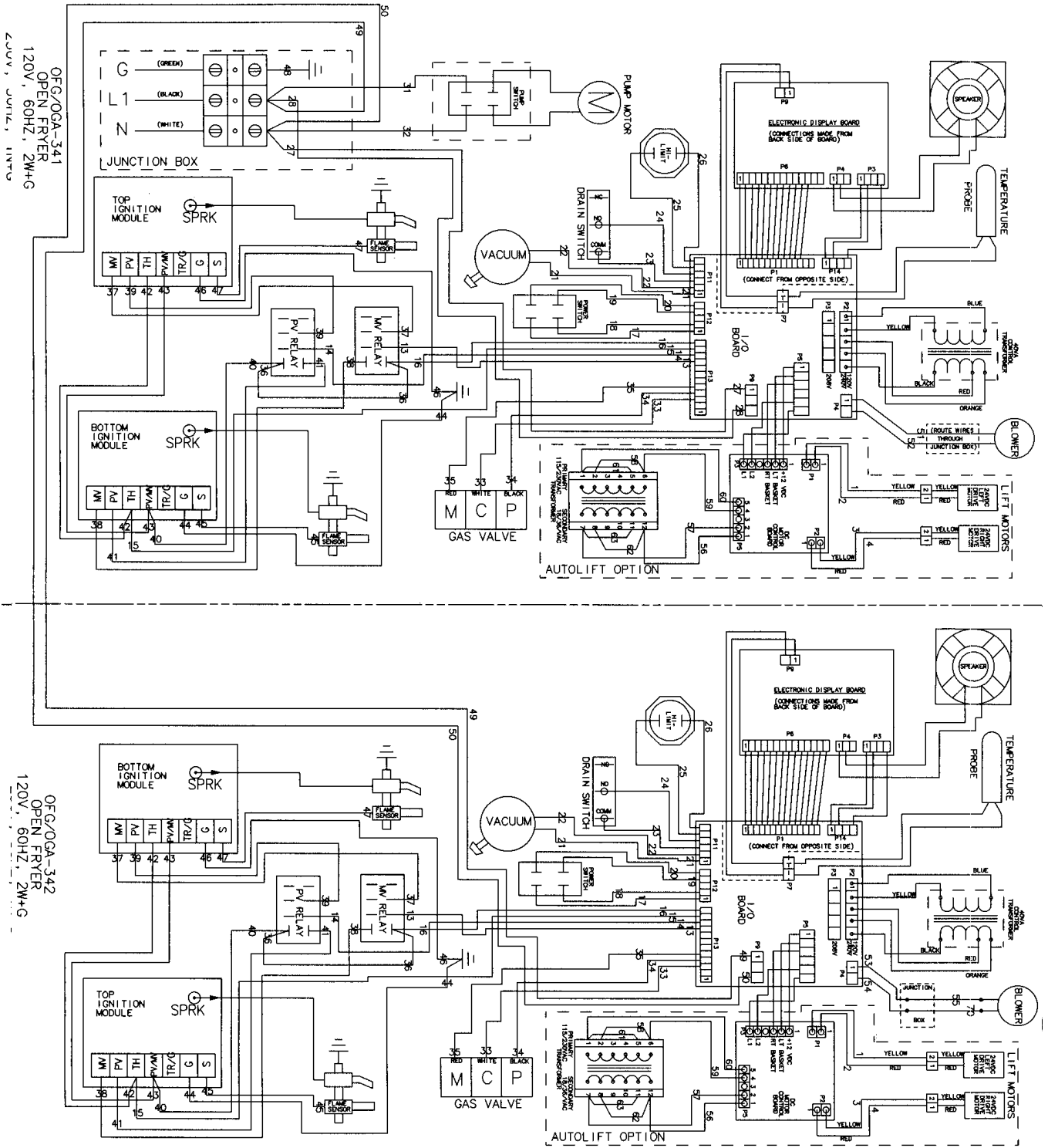

Drain switch wired N/O

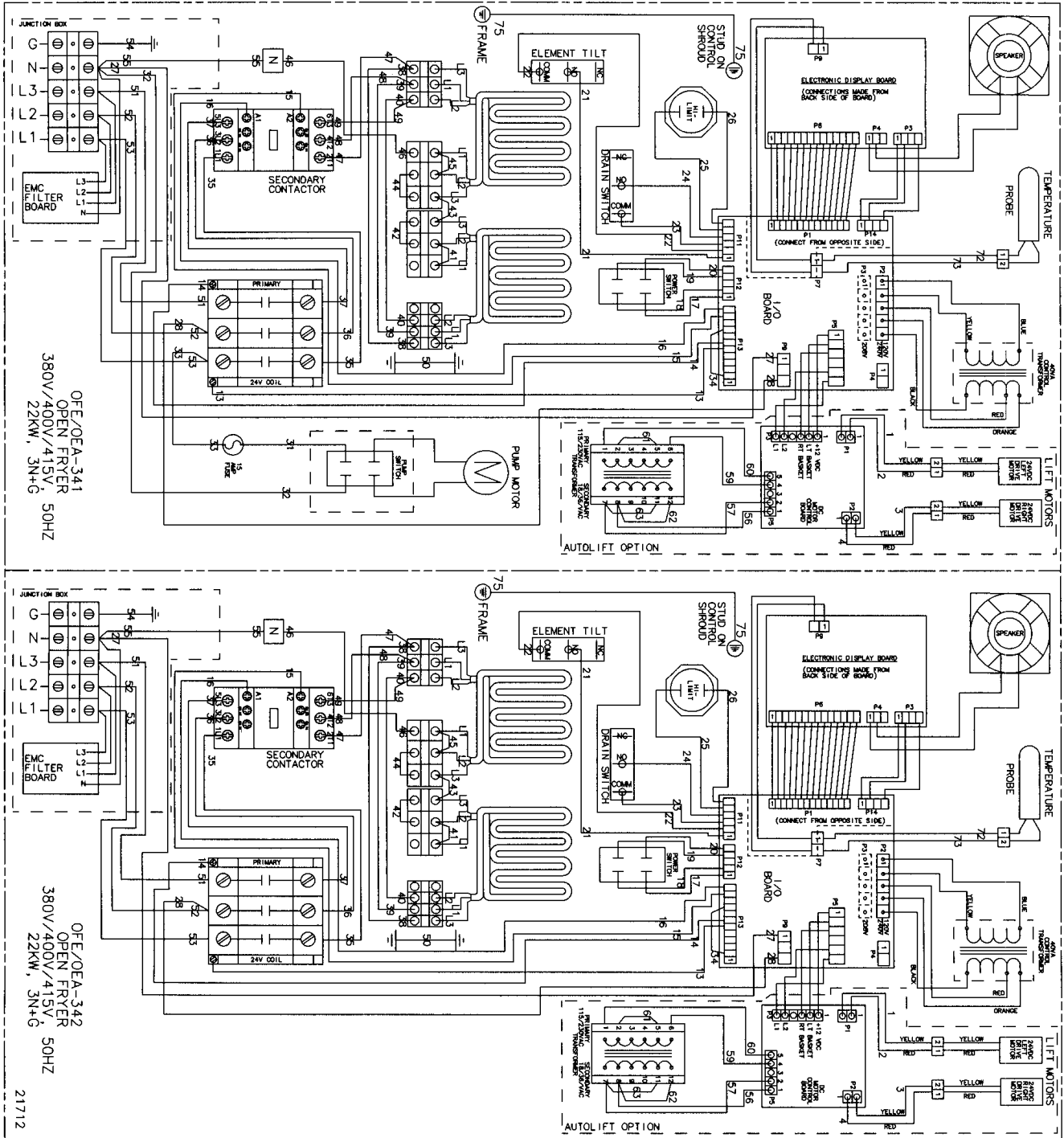

Drain switch wired N/O

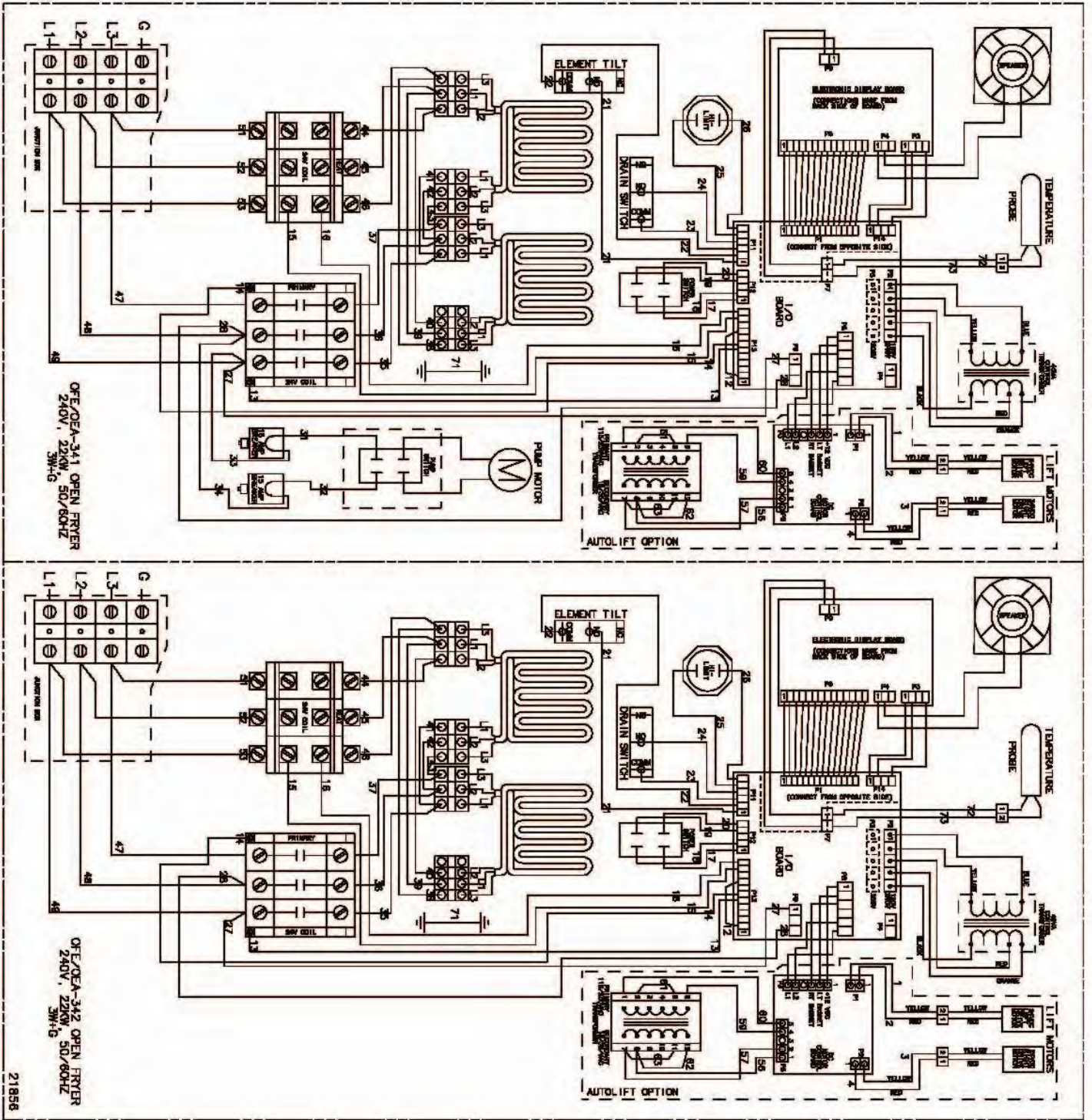

Drain switch wired N/O

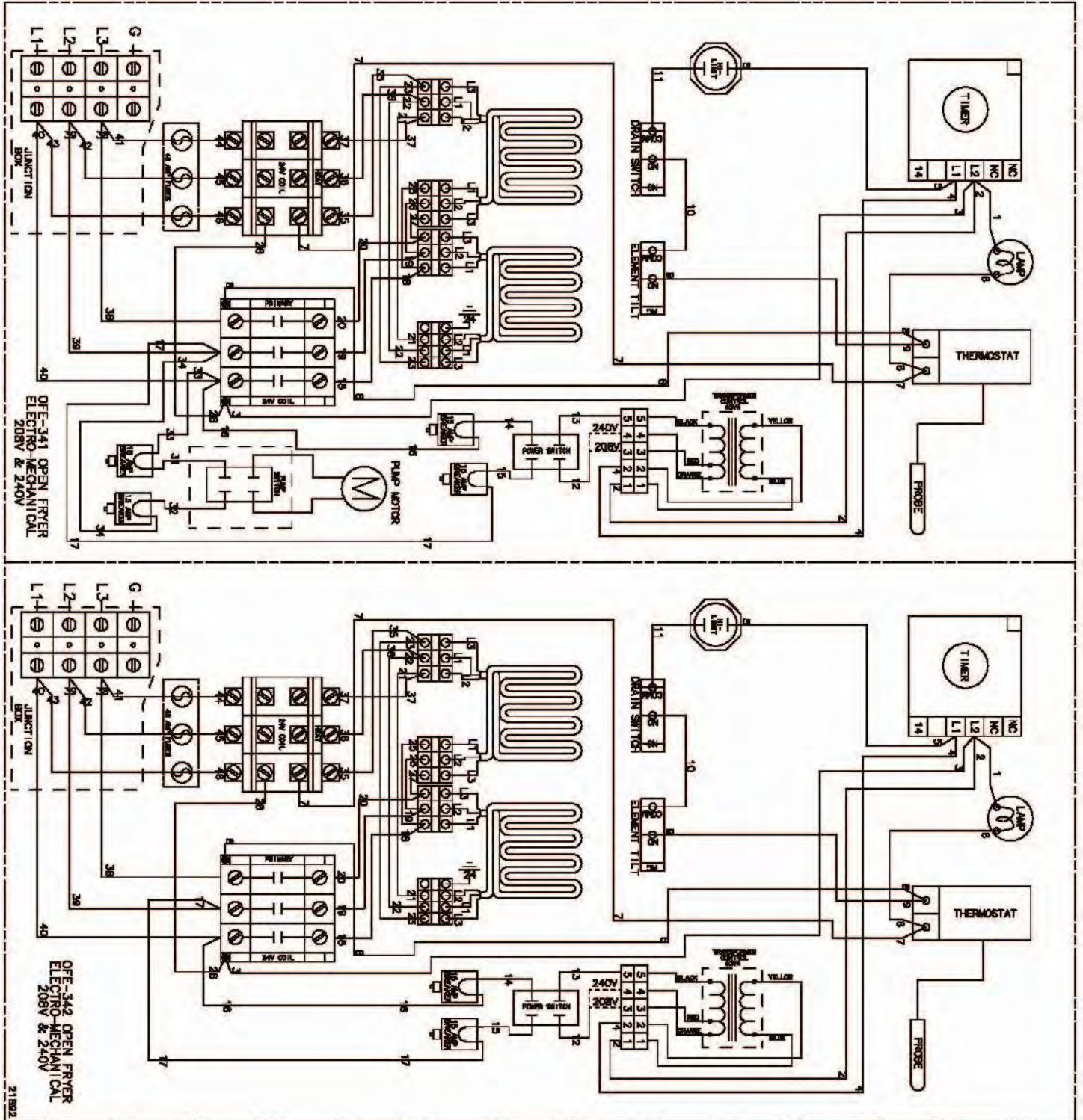

Drain switch wired N/O

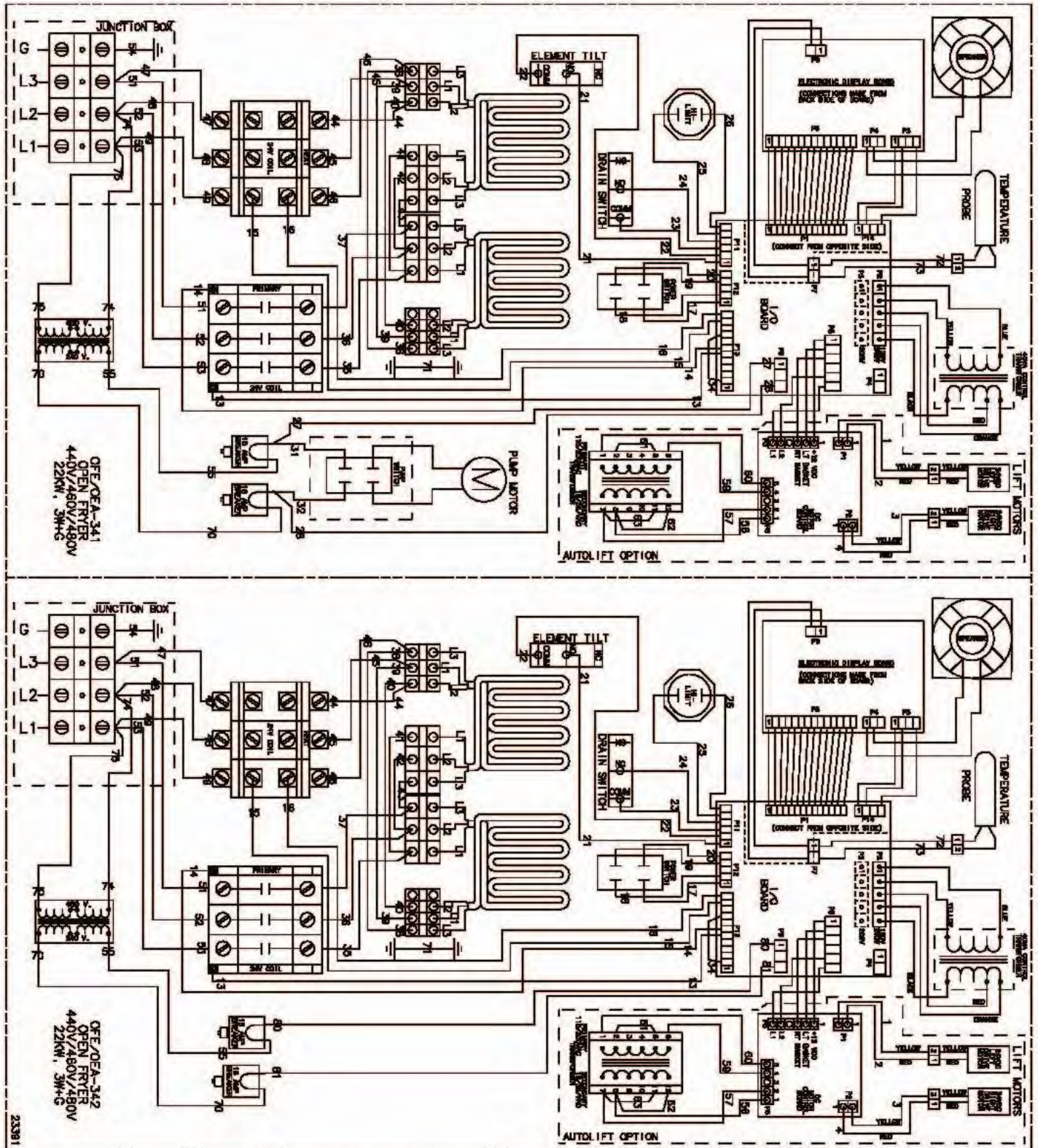

Drain switch wired N/C

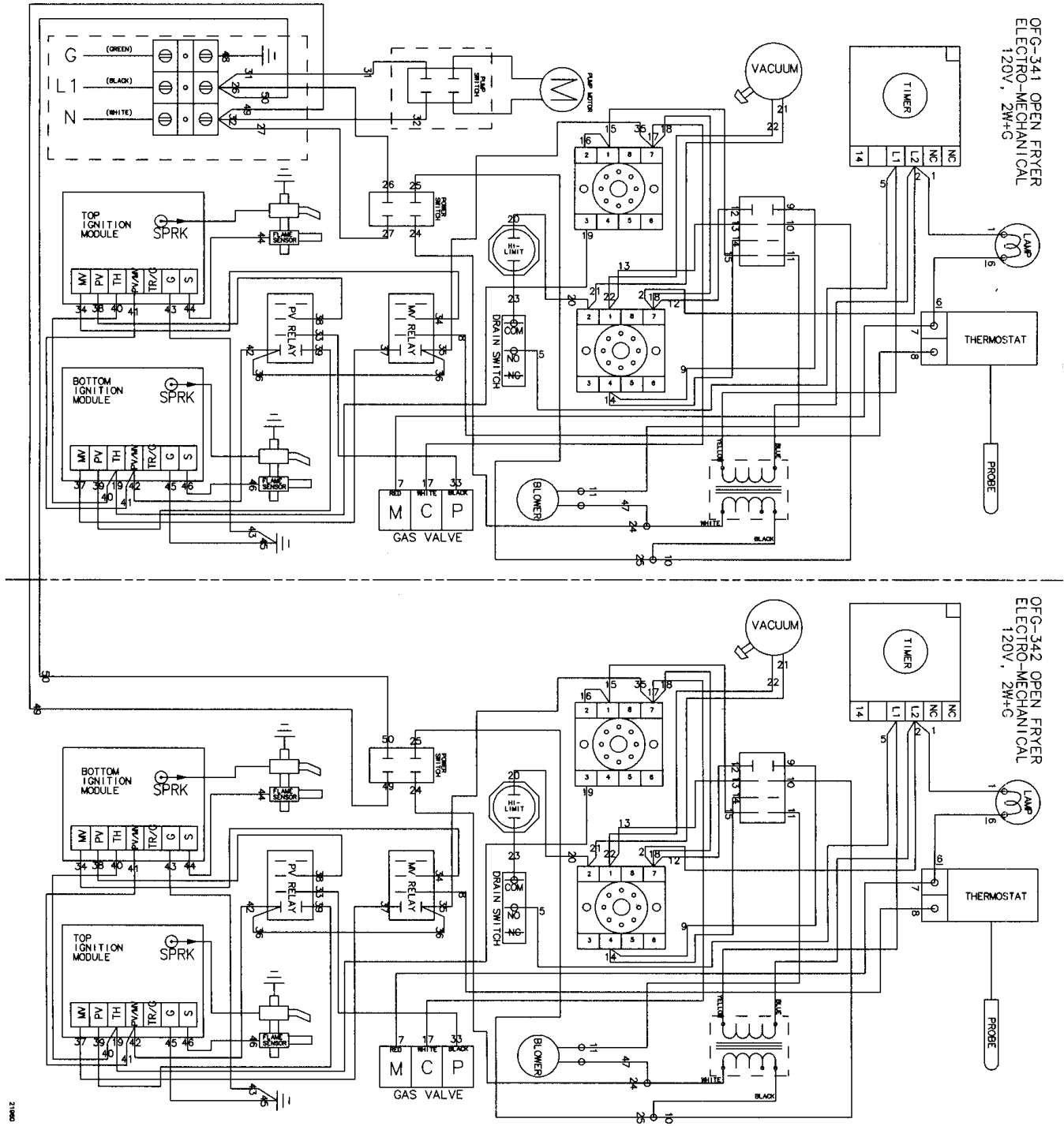

Drain switch wired N/C