

# Counter Warmer CW-100 Owner's Manual

Manufacturing Numbers:  
9400186 & 9400187

# Table of Contents

## Overview

- Before Use
- In Case of Damage
- Website

## Service/Technical Assistance

- Equipment Information to Save
- Authorized Service Agency

## Safety Information Page

- Installation
- Maintenance
- Service

## Specifications

- Electrical Ratings

## Installation

- Unpacking

## Operation

## Maintenance

- Daily Cleaning
- Cleaning Scale

## Hi-Limit Control

## Replacement Parts List

## Replacement Parts Views

## Limited Warranty

# Overview

- 2 This appliance is intended to be used to
- 2 hold food at temperature for an extended
- 2 period of time but NOT for the production
- 2 or cooking of food.

## Before Use

- 2 This manual contains safety, installation,
- 2 and operating procedures for the unit.
- 3 Read and understand it completely be-
- 3 fore installing or operating the unit. Keep
- 3 this document for reference. If the unit
- 3 changes ownership, this manual must
- 4 accompany it.

## In Case of Damage

- 5 If the unit arrives damaged, file a claim
- 5 with the carrier immediately. Save all
- 5 packing materials when filing a claim.
- 5 Freight damage claims are the respon-
- 6 sibility of the purchaser and are not
- 6 covered under warranty.

## Website

[www.antunes.com](http://www.antunes.com)

# Service/Technical Assistance

If any parts are missing or damaged, contact Antunes Customer Service immediately at +1-877-392-7856 (toll free).

If there are problems with the installation or operation of this product, contact Antunes Technical Service toll free at +1-877-392-7854.

Fill in the information below and have it handy when calling for assistance. The serial number is on the specification plate located on the system.

## Equipment Information to Save

Purchased from:

---

Date of purchase:

---

Model number:

---

Serial number:

---

Manufacturing number:

---

## Authorized Service Agency

Name:

---

Phone No:

---

Address:

---

# Safety Information Page

## Installation

- Read and understand all instructions before installing or using the unit.
- Install this unit to comply with the basic plumbing code of the Building Officials and Code Administrators, Inc. (BOCA) and the Food Service Sanitation Manual of the Food and Drug Administration (FDA).
- Install and locate the equipment only for its intended use as described in this manual.

## Operation

- The unit is furnished with a properly grounded cord connector. Do not attempt to defeat the grounded connector.
- Do not operate the unit if it has been damaged or dropped, if it has a damaged cord or plug, or if it is not working properly.
- Do not block or cover any openings on the equipment.
- Do not immerse the cord, unit, or plug in water.
- Keep the cord away from heated surfaces.
- Do not allow the cord to hang over the edge of a table or counter

## WARNING

**ELECTRICAL SHOCK HAZARD.**  
**Failure to follow the instructions in this manual could result in serious injury or death.**

Do not modify the power supply cord plug. If it does not fit the outlet, have a proper outlet installed by a qualified electrician.

Electrical ground is required on this appliance.

Check with a qualified electrician if you are unsure if the appliance is properly grounded.

Do NOT use an extension cord with this product.

The unit should be grounded according to local electrical codes to prevent the possibility of electrical shock. It requires a grounded receptacle with separate electrical lines, protected by fuses or circuit breaker of the proper rating.

NEVER unplug the power cord while the unit is running. Use the proper shutdown procedure before unplugging the power cord.

This appliance can be used by children aged from 8 years and above and persons with reduced physical, sensory or mental capabilities or lack of experience and knowledge if they have been given supervision or instruction concerning use of the appliance in a safe way and understand the hazards involved. Children shall not play with the appliance. Cleaning and user maintenance shall not be made by children without supervision.

This appliance is NOT to be cleaned with a water jet.

If the malfunction light goes on, the appliance is malfunctioning. Turn off or disconnect appliance from power supply and have serviced by a qualified technician.

## Maintenance

- Do not use abrasive materials; they can damage the unit's stainless steel finish.
- Do not use corrosive chemicals in this equipment.
- Chlorides or phosphates in cleaning agents (e.g., bleach, sanitizers, degreasers, and detergents) can permanently damage stainless steel equipment. The damage is usually in the form of discoloration, dulling of the metal surface finish, pits, voids, holes, or cracks. This damage is permanent and is not covered by warranty.
- Always use a soft, damp cloth for cleaning. Rinse with clear water and wipe dry. When required, always rub in the direction of metal polish lines.
- Routine cleaning should be performed daily with soap and water.
- Rub off finger marks and smears using soap and water.
- Do not clean unit or components in a dishwasher unless specifically specified in the cleaning instructions.
- Do not clean the unit with a water jet or steam cleaner.

## Service

- Inspection, testing, and repair of electrical equipment must be performed only by qualified service personnel.
- To avoid possible personal injury and/or damage to the unit, all inspections, tests, and repair of electrical equipment should be performed by qualified personnel ONLY. Contact Antunes Technical Service for adjustment or repair.
- Turn the power off, unplug the power cord, and allow unit to cool to room temperature before performing any service or maintenance.
- If the supply cord is damaged, it must be replaced by the manufacturer, its service agent, or a similarly qualified person in order to avoid an electrical hazard.
- Cleaning and user maintenance shall not be made by children without supervision.

# Specifications

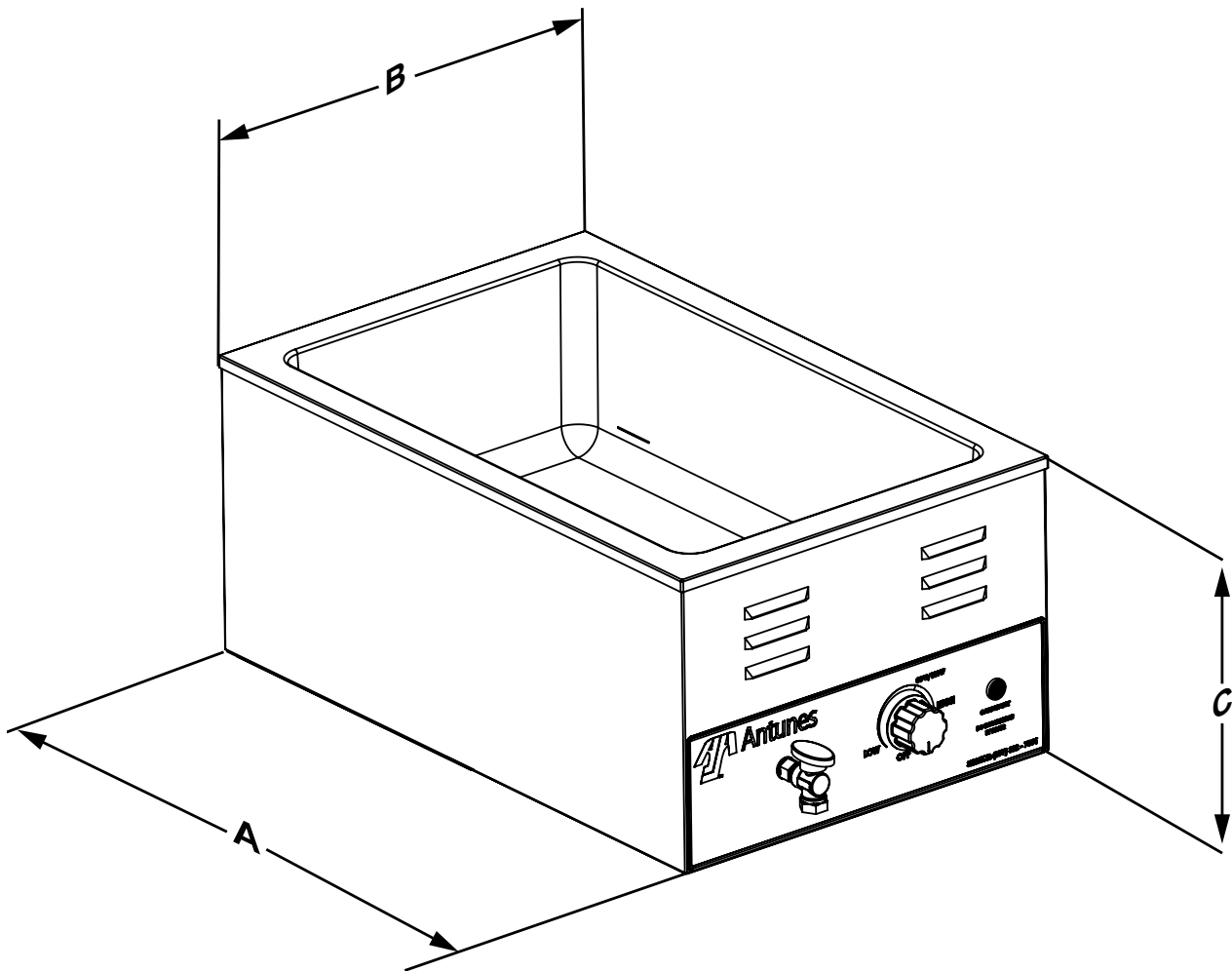

## Electrical Ratings

Mfg. No.	Volts	Watts	Amps	Hertz	Plug Description	Plug Configuration
9400186	120	1200	10	50/60	NEMA 5-15P, 15 Amp., 120 VAC	
9400187	230	1200	5.2	50/60	CEE 7/7, 16 Amp., 250 VAC	

Mfg. No.	(A) Width	(B) Depth	(C) Height
9400186	17.39"	16.86"	12.79"
9400187	(441.7mm)	(428.24mm)	(324.87mm)

## Installation

### Unpacking

1. Remove unit and all packing materials from shipping carton.
2. Open the large box. Remove all packing materials and protective coverings from the unit and parts.

**NOTE:** If any parts are missing or damaged, contact Antunes Customer Service IMMEDIATELY at +1-877-392-7856 (toll free).

3. Place the unit on a flat, stable, non-combustible surface near the power source.
4. Wipe all surfaces of the unit with clean, sanitized towel.

**NOTE:** Do NOT use a dripping wet cloth. Wring out before use.

### Operation

1. Plug the power cord into a grounded electrical outlet of the correct voltage. The indicator light will turn on, to show that the unit is on and warming.
2. Fill the sink with approximately 1/2 inch of water. Do not allow water level to go higher than this.
3. Preheat the water in the sink: Covering the sink with an empty food container or cover. Set heat control knob to the maximum heat setting 212 °F(100 °C) for the recommended time: **40 minutes to reach maximum temperature if the sink contains COLD water.**

**NOTE:** The warmer is intended to hold containers of **previously cooked**, hot food at the proper temperature. The warmer should NOT be used to cook food.

4. Place stainless steel containers (insets) of food into warmer. Cover inset with lid. To prevent spills, do not overfill the food container.
5. Do not put food product directly into the warmer sink. Food must always be placed in an inset.
6. For the function of hot food holding, set the heat control knob to the desired setting. Monitor food temperatures closely for food safety. It is the responsibility of the operator to make sure that food is maintained at a safe temperature for serving. The insets must be covered to maintain temperatures when food is not being served.
7. During normal operation for food holding, periodically remove container and check water level. Add hot water if necessary. Stir occasionally.
8. Turn warmer off when not in use. To disconnect appliance, turn controls off and remove plug from power source.

**NOTE:** These warmers are designed to operate with water in the sink. Wet operation is necessary to maintain safe food temperatures, for more even heat distribution, lower operating costs and longer trouble free service. Food insets must be covered to maintain temperature when food is not being served.

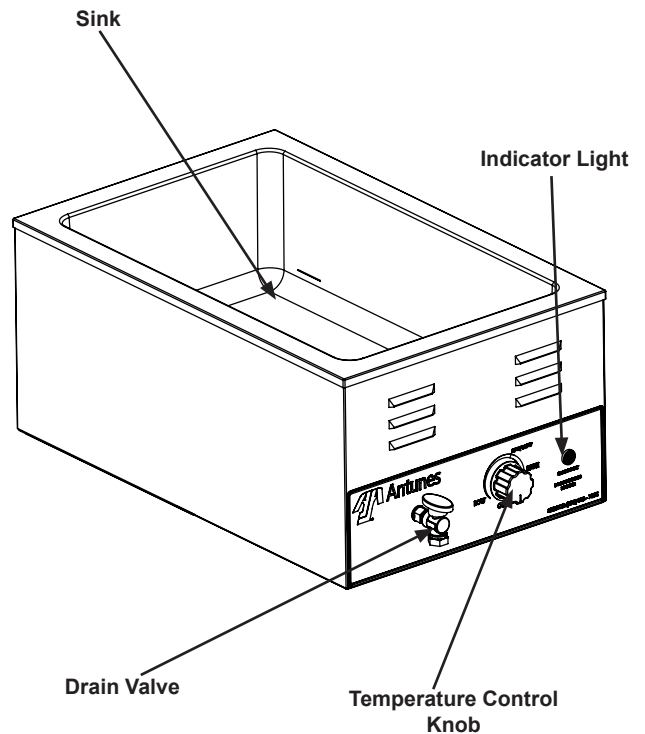

Figure 1. Warmer Components

## Maintenance

### Daily Cleaning

1. Turn the unit off by turning the controls off and unplugging the power cord.
- NOTE:** You do not need to wait until the unit is completely cool to be cleaning. However, the unit will be hot so wear heat resistant gloves during cleaning.
2. Put on heat resistant gloves and remove the cover and food inset.
  3. Wash, rinse, and sanitize the cover and food inset. Allow to air dry.
  4. Wipe the exterior of the unit and the inner part of the basket cavity with a clean, sanitized towel. Clean up any spills completely. Allow to air dry.

**NOTE:** If soap or chemical cleaners are used, be sure they are completely rinsed away with clear water immediately after cleaning. Chemical residue could damage the warmer.

### Cleaning Scale

**NOTE:** Frequency of cleaning scale is determined by water conditions and usage.

1. Turn the unit off by turning the controls off and unplugging the power cord.
2. Combine 1 tsp. of white vinegar to 1 cup of water. Pour into sink and let stand. More of this solution may be needed depending on the amount of scale in the sink.
3. Drain the sink of the vinegar solution and rinse with clear water.
4. Repeat these steps if necessary.

## Hi-Limit Control

A Hi-Limit Control turn off electrical power to the heaters if the unit overheats.

To reset the control:

1. Let the unit cool for 15 minutes.
2. Located the Hi-Limit Control on the rear of the unit. Remove the red protective cap.
3. Press and release the button. Reinstall the protective cap.

**NOTE:** If the Hi-Limit Control Requires continuous resetting, contact your Authorized Service Agency.

## Replacement Parts List

### NOTE

Use only genuine Antunes replacement parts in this unit. Use of replacement parts other than those supplied by the manufacturer will void the warranty.

Item No.	Part #	Description	Qty.
1	0024135	Pan, Weldment	1
2	0024275	Weldment, Body Housing	1
3	0025108	Distribution Heater	
4	040P119*	Bushing, Shorty 5/8	1
5	040P138*	Conduit Locknut 1/2"	1
6	0400251	Strain Relief Cord Connector	1
7	0400636	Insulator, CW-100	1
8	0509117	Bottom Cover	1
9	0512117	Shell Cover, Calrod Heater	1
10	0512118	Mounting Bracket	2
11	0700463	Power Cord-EURO CE-501S Plug 16A, 250VAC Mfg No 9400186 ONLY	1
	0701100	Power Cord NEMA 14/3 5-15P Plug Mfg No 9400187 ONLY	1
12	1002764	Label, Panel Mfg No 9400186 ONLY	1
	1002746	Label, GUI Interface Mfg No 9400187 ONLY	1
13	2100295	Foot, Rubber	4
14	2100386	Knob, CW-100	1
15	2170170	Valve, Angular 3/8 NPT	1
16	306P101*	Nut, Hex #06-32 ST.STL	-
17	306P123*	Screw, Mach. #6-32 X 7/8" SLRNDHD	-
18	308P120	Screw, Mach.. #8-32 x 5/8"	4
19	308P124*	Screw, Mach. #8-32 X 1/2, 1-Way	-
20	3080199	Nut, Hex KEPS #8-32 S/S	2

Item No.	Part #	Description	Qty.
21	308P203*	Screw, 8-32 X 3/8 with Int. Tooth Washer	-
22	310P146*	Nut, Hex KEPS #10-32	-
23	310P157*	Washer, Flat #10	-
24	3100167	Washer, Split Lock #10	4
25	3100241	Nut, Hex ##10-32 UNF S.S.	4
26	4030506	Thermostat, EGO	1
27	4030527	Thermostat, Hi-Limit	1
28	4030537	Heating Element, 120V 1200W Mfg No 9400186 ONLY	1
	4030548	Heating Element, 230V 1200W Mfg No 9400187 ONLY	1
29	4060304	Terminal Block, 3 Wire	1
30	4060323	Indicator Light, Amber 250V Mfg No 9400186 ONLY	1
	4060229	Indicator Light, Amber 125V Mfg No 9400187 ONLY	1
31	4060377	Cable Tie Mount w/ Adhesive	4
32	0701148	Wire Set, CW-100	1

\* Can only be order in packages of ten (10).

# Replacement Parts Views

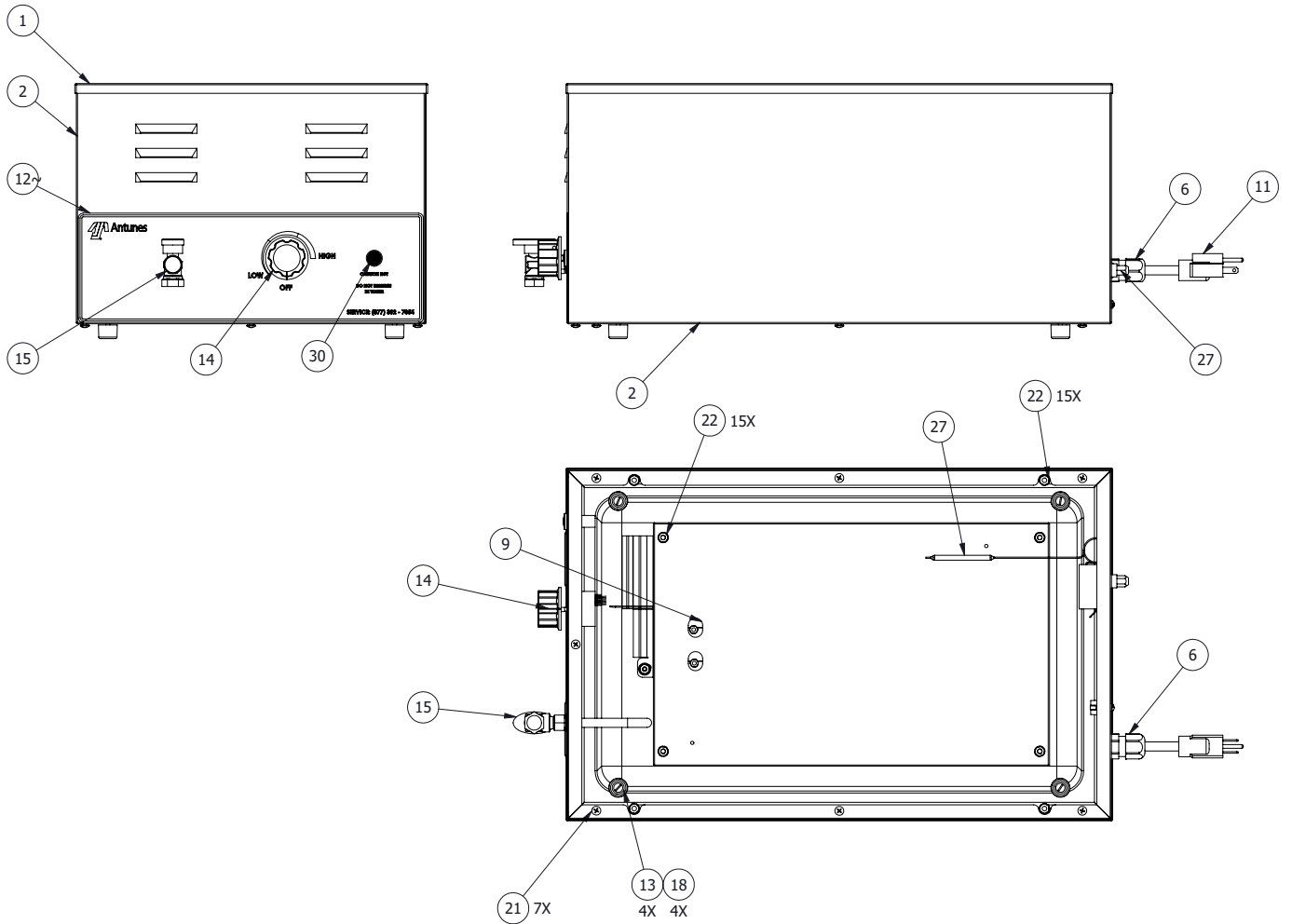

## Limited Warranty

Equipment manufactured by Antunes has been constructed of the finest materials available and manufactured to high quality standards. These units are warranted to be free from electrical and mechanical defects for a period of one (1) year from date of purchase under normal use and service, and when installed in accordance with manufacturer's recommendations. To insure continued operation of the units, follow the maintenance procedures outlined in the Owner's Manual. During the first 12 months, electromechanical parts, non-overtime labor, and travel expenses up to 2 hours (100 miles/160 km), round trip from the nearest Authorized Service Center are covered.

1. This warranty does not cover cost of installation, defects caused by improper storage or handling prior to placing of the Equipment. This warranty does not cover overtime charges or work done by unauthorized service agencies or personnel. This warranty does not cover normal maintenance, calibration, or regular adjustments as specified in operating and maintenance instructions of this manual, and/or labor involved in moving adjacent objects to gain access to the equipment. This warranty does not cover consumable/wear items. This warranty does not cover damage to the Load Cell or Load Cell Assembly due to abuse, misuse, dropping of unit/shock loads or exceeding maximum weight capacity (4 lbs). This warranty does not cover water contamination problems such as foreign material in water lines or inside solenoid valves. It does not cover water pressure problems or failures resulting from improper/incorrect voltage supply. This warranty does not cover Travel Time & Mileage in excess of 2 hours (100 miles/160 km) round trip from the nearest authorized service agency.
2. Antunes reserves the right to make changes in design or add any improvements on any product. The right is always reserved to modify equipment because of factors beyond our control and government regulations. Changes to update equipment do not constitute a warranty charge.
3. If shipment is damaged in transit, the purchaser should make a claim directly upon the carrier. Careful inspection should be made of the shipment as soon as it arrives and visible damage should be noted upon the carrier's receipt. Damage should be reported to the carrier. This damage is not covered under this warranty.
4. Warranty charges do not include freight or foreign, excise, municipal or other sales or use taxes. All such freight and taxes are the responsibility of the purchaser.

This warranty is exclusive and is in lieu of all other warranties, expressed or implied, including any implied warranty or merchantability or fitness for a particular purpose, each of which is hereby expressly disclaimed. The remedies described above are exclusive and in no event shall Antunes be liable for special consequential or incidental damages for the breach or delay in performance of this warranty.

The warranty does not extend to:

- Damages caused in shipment or damage as result of improper use.
- Installation of electrical service.
- Installation, calibration, or adjustment.
- Normal maintenance outlined in this manual.
- Malfunction resulting from improper service or maintenance.
- Damage caused by improper installation, abuse, or careless handling.
- Damage from moisture getting into electrical components.
- Damage from tampering with, removal of, or changing any preset control or safety device.
- Damage caused by parts or components not provided by Antunes



#### Corporate Headquarters

Carol Stream, Illinois  
Phone: +1 (630) 784-1000  
Toll Free: +1 (800) 253-2991  
Fax: +1 (630) 784-1650

#### China Facility

Suzhou, China  
Phone: +86-512-6841-3637  
Fax: +86-512-6841-3907