

Butter Wheel unit shown

# Vertical Contact Toaster

## Model VCTM-2

### Owner's Manual

Manufacturing Number  
9210914, 9210916, 9210959,  
9210960 & 9210983



## Table of Contents

<b>Overview</b> .....	<b>2</b>
Before Use .....	2
In Case of Damage .....	2
Website .....	2
<b>Service/Technical Assistance</b> .....	<b>2</b>
In Case of Damage .....	2
Equipment Information to Save.....	2
<b>Safety Information</b> .....	<b>3</b>
Installation .....	3
Operation .....	3
Maintenance.....	3
Service .....	3
<b>Specifications</b> .....	<b>4</b>
<b>Installation</b> .....	<b>5</b>
Unpacking .....	5
Equipment Setup.....	5
Assembling the Unit .....	5
<b>Installation</b> .....	<b>6</b>
<b>Operating Instructions</b> .....	<b>7</b>
<b>Default Settings</b> .....	<b>7</b>
Recommended temperatures.....	7
Recommended Speed Setting .....	7
Light/Dark Setting.....	7
Viewing Settings.....	8
Changing Settings.....	8
Factory Reset.....	8
Hi-Limit Reset Button .....	8
<b>Fault Codes</b> .....	<b>9</b>
<b>Maintenance</b> .....	<b>10</b>
Daily Cleaning .....	10
Quarterly Cleaning .....	11
Replacing the Belt Wraps.....	12
Checking the Conveyor Belt Chains ...	13
Replacing Conveyor Belt Chains .....	13
<b>Troubleshooting</b> .....	<b>14</b>
<b>Wiring Diagram</b> .....	<b>15</b>
<b>Replacement Parts</b> .....	<b>16</b>
Parts List .....	16
<b>Exploded Views</b> .....	<b>18</b>
Exploded View #1 .....	18
Exploded View #2 .....	19
Exploded View #3 .....	20
Exploded View #4 .....	21
<b>Notes</b> .....	<b>22</b>
<b>Notes</b> .....	<b>23</b>
<b>Limited Warranty</b> .....	<b>24</b>

## Overview

This unit is intended to be used for commercial applications, for example: in kitchens of restaurants, canteens, hospitals and in commercial enterprises such as bakeries, butcheries, etc., But not for continuous mass production of food.

### Before Use

This manual contains safety, installation, and operating procedures for the unit. Read and understand it completely before installing or operating the unit. Keep this document for reference. If the unit changes ownership, this manual must accompany it.

### In Case of Damage

If the unit arrives damaged, file a claim with the carrier immediately. Save all packing materials when filing a claim. Freight damage claims are the responsibility of the purchaser and are not covered under warranty.

### Website

[www.antunes.com](http://www.antunes.com)

## Service/Technical Assistance

### In Case of Damage

If any parts are missing or damaged, problems with the installation or operation of this product contact Antunes Customer Service immediately toll free at +1-877-392-7856.

If there are problems with the installation or operations of this product, contact Antunes Technical Service toll free at +1-877-392-7854.

Fill in the information in the next section and have it ready when calling for assistance. The serial number is on the specification sticker located on the system.

### Equipment Information to Save

Purchased from:

---

Date of purchase:

---

Model number:

---

Serial number:

---

Manufacturing number:

---

### Authorized Service Agency

Name:

---

Phone No:

---

Address:

---

## Safety Information

### Installation

- Read and understand all instructions before installing or using the unit.
- Install this unit to comply with the basic plumbing code of the Building Officials and Code Administrators, Inc. (BOCA) and the Food Service Sanitation Manual of the Food and Drug Administration (FDA).
- Install and locate the equipment only for its intended use as described in this manual.

### WARNING

#### **ELECTRICAL SHOCK HAZARD.** **Failure to follow the instructions in this manual could result in serious injury or death.**

Do not modify the power supply cord plug. If it does not fit the outlet, have a proper outlet installed by a qualified electrician.

Electrical ground is required on this appliance.

Check with a qualified electrician if you are unsure if the appliance is properly grounded.

Do NOT use an extension cord with this product.

The unit should be grounded according to local electrical codes to prevent the possibility of electrical shock. It requires a grounded receptacle with separate electrical lines, protected by fuses or circuit breaker of the proper rating.

NEVER unplug the power cord while the unit is running. Use the proper shutdown procedure before unplugging the power cord.

## Operation

- The unit is furnished with a properly grounded cord connector. Do not attempt to defeat the grounded connector.
- Do not operate the unit if it has been damaged or dropped, if it has a damaged cord or plug, or if it is not working properly.
- Do not block or cover any openings on the equipment.
- Do not immerse the cord, unit, or plug in water.
- Keep the cord away from heated surfaces.
- Do not allow the cord to hang over the edge of a table or counter.
- This appliance is not to be used by persons (including children) with reduced physical, sensory or mental capabilities, or lack of experience and knowledge unless they have been given supervision or instruction.
- Children being supervised are not to play with the appliance.
- Bread may burn. Therefore toasters must not be used near or below curtains or other combustible walls and materials. Failure to maintain safe operating distances may cause discoloration or combustion.

## Maintenance

- Do not use abrasive materials; they can damage the unit's stainless steel finish.
- Do not use corrosive chemicals in this equipment.
- Chlorides or phosphates in cleaning agents (e.g., bleach, sanitizers, degreasers, and detergents) can permanently damage stainless steel equipment. The damage is usually in the form of discoloration, dulling of the metal surface finish, pits, voids, holes, or cracks. This damage is permanent and is not covered by warranty.
- Always use a soft, damp cloth for cleaning. Rinse with clear water and wipe dry. When required, always rub in the direction of metal polish lines.
- Routine cleaning should be performed daily with soap and water.
- Rub off finger marks and smears using soap and water.
- Do not clean unit or components in a dishwasher unless specifically specified in the cleaning instructions.
- Do not clean the unit with a water jet or steam cleaner.

## Service

- Inspection, testing, and repair of electrical equipment must be performed only by qualified service personnel.
- To avoid possible personal injury and/or damage to the unit, all inspections, tests, and repair of electrical equipment should be performed by qualified personnel ONLY. Contact Antunes Technical Service for adjustment or repair.
- Turn the power off, unplug the power cord, and allow unit to cool to room temperature before performing any service or maintenance.
- If the supply cord is damaged, it must be replaced by the manufacturer, its service agent, or a similarly qualified person in order to avoid an electrical hazard.
- Cleaning and user maintenance shall not be made by children without supervision.

# Specifications

## Electrical Ratings

Model & Mfg. No.	Volts	Watts	Amp	Hertz	Description
VCTM-2 9210914 (Butter Wheel)	208-230	3100	14.9/13.4	50/60	IEC-309, 16 Amp., 250V
VCTM-2 9210916 (No Butter Wheel)					
VCTM-2 9210959 (No Butter Wheel)					
VCTM-2 9210960 (No Butter Wheel)					NEMA 6-20P, 20 Amp., 250V Right Angle
VCTM-2 9210983 (No Butter Wheel)					BS-1363 Fused, 13Amp., 250V

## Dimensions

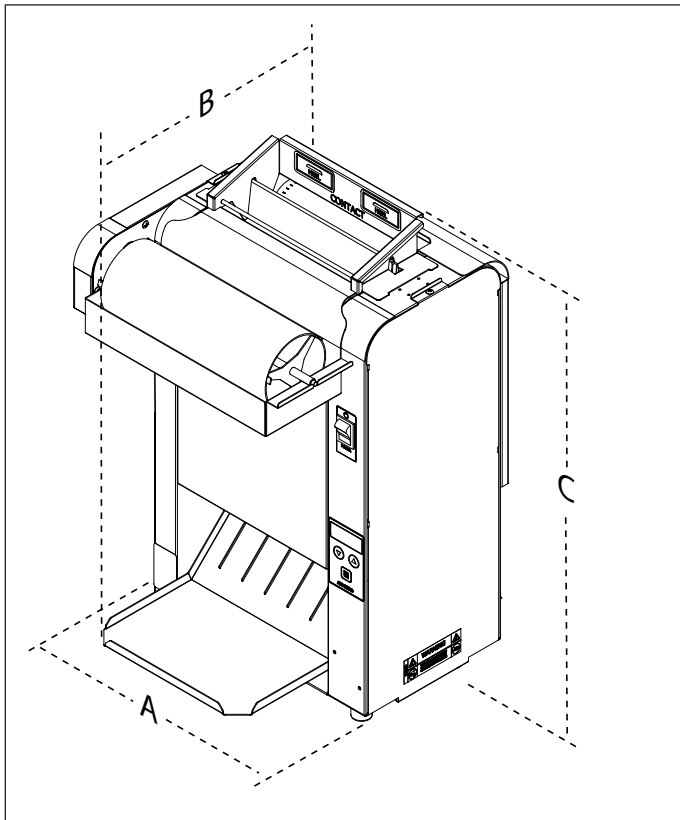

Model & Mfg. No.	Width (A)	Depth (B)	Height (C)
VCTM-2 9210914 (Butter Wheel)	14" (356 mm)	15 1/2" (394 mm)	25 1/2" (648 mm)
VCTM-2 9210916 (No Butter Wheel)			
VCTM-2 9210959 (No Butter Wheel)			
VCTM-2 9210960 (No Butter Wheel)			
VCTM-2 9210983 (No Butter Wheel)			

# Installation

## Unpacking

1. Remove unit and all packing materials from shipping carton.
2. Open the included large box. It should contain the following (See Figure 3):
  - Bun Chute
  - Butter Wheel and Pan (Mfg. No. 9210914)
  - Bun Feeder
  - Two guttered Release Sheets
  - Platen Cleaning Tool
  - Owner's Manual
  - Maintenance Card
3. Remove all shipping tape and protective coverings from the unit and parts.

**NOTE:** Missing or damaged parts? Contact Antunes Customer Service at +1-877-392-7856 (toll free).

## Equipment Setup

Before placing the toaster into service, pay attention to the following guidelines:

- Make sure power to the unit is off and the toaster is at room temperature.
- Do NOT block or cover any openings on the unit.
- Do NOT immerse cord or plug in water.
- Keep cord away from heated surfaces.
- Do NOT allow cord to hang over edge of table or counter.
- Connect the unit to the proper power supply. Refer to the specification plate for proper voltage.

## Assembling the Unit

**NOTE:** The factory has pre-installed a Release Sheet over the Platen (Figure 3). Verify that it is properly in place before proceeding.

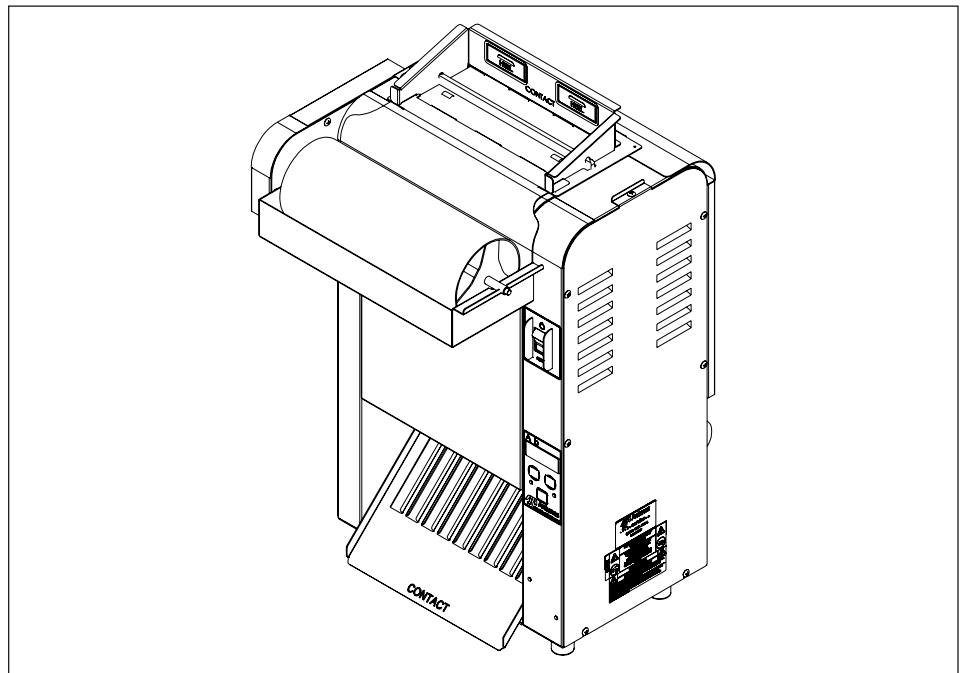

Figure 1. VCTM-2

## Installing Butter Wheel Assembly (Mfg. No. 9210914 ONLY)

1. Remove Butter Wheel and Pan from box.
2. Install the Pan over the front edge of the Bun Feeder and place the Butter Roller in Pan and engage into gear case (Figure 2).
3. Fill the Butter Pan with Butter before toasting.

## Installing the Bun Chute

1. If the unit is on, be sure to put on heat resistant gloves.
2. Insert the Bun Chute through the front of the unit according to Figure 2.
3. Hang the back of the Bun Chute on the rear Conveyor Cover hinge. When properly installed, the Bun Chute supports will be flush against the front of the unit (Figure 2).

**NOTE:** You may need to stand to the side of the unit to guide the front and rear using both hands.

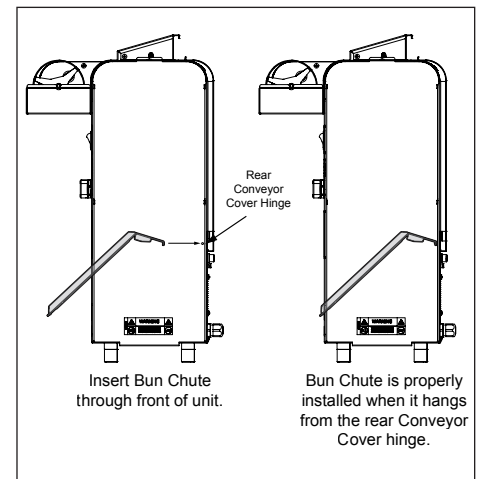

Figure 2. Installing Bun Chute



Failure to use Release Sheets may result in damage to the unit and loss of warranty coverage.

# Installation

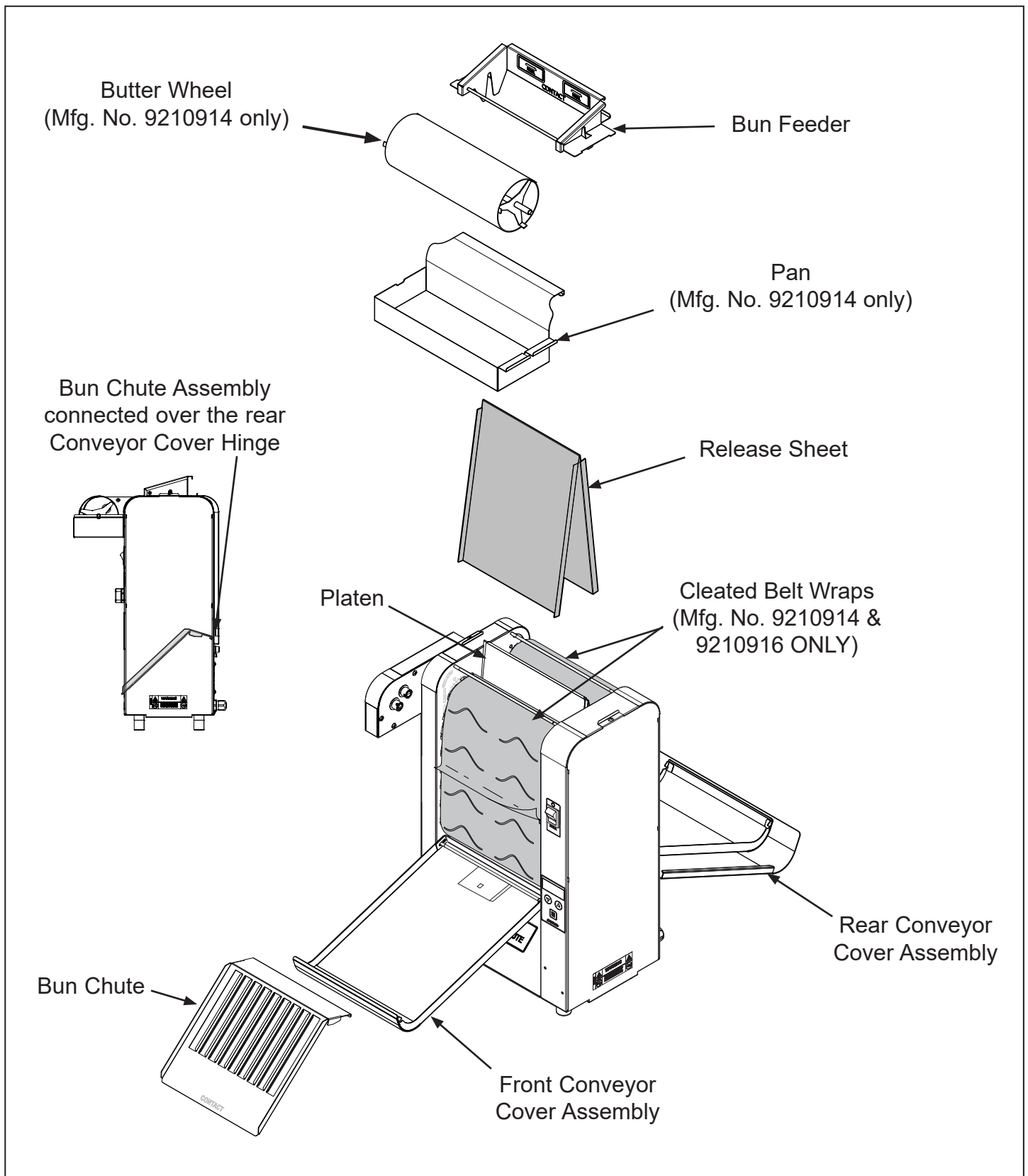

Figure 3. Components

## Operating Instructions

1. Set the Bun Thickness Adjustment Controls (Figure 4).

**NOTE:** Your individual customer or store requirements are the deciding factor on the finished product, not the Bun Thickness setting.

**NOTE:** The default Bun Thickness settings are 2 for Crown Front and 2 for Heel Rear, but settings are adjustable from 1-6. It is acceptable to adjust the Bun Thickness setting as needed to achieve the desired quality toast and bun compression.

2. Turn the power on and wait until the display reads USE before proceeding.

**NOTE:** The display (Figure 4) flashes "LO" during warm-up. "USE" appears when the toaster is ready for use.

3. Fill the Butter Pan (Mfg. No. 9210914 only).
4. Slide buns across the rotating Butter Wheel with the cut face down (Mfg. No. 9210914 only). Drop buns into the Bun Feeder. Insert buns so they face the center platen. The cut sides of heel and crown must face each other and slide against the Release Sheet with Crowns inserted in the front and Heels inserted in the rear.
5. Toasted buns drop onto the Bun Chute (Figure 4).
6. Test at least 4 buns before putting the toaster into service.

## Default Settings

### Recommended temperatures

The default and recommended temperature setting for the A platen heater is 293° C (560° F).

The default and recommended temperature setting for the B Platen heater is 218° C (424° F).

### Recommended Speed Setting

The default and recommended speed setting is 1400 for 22 second pass-through (plus or minus 2 seconds).

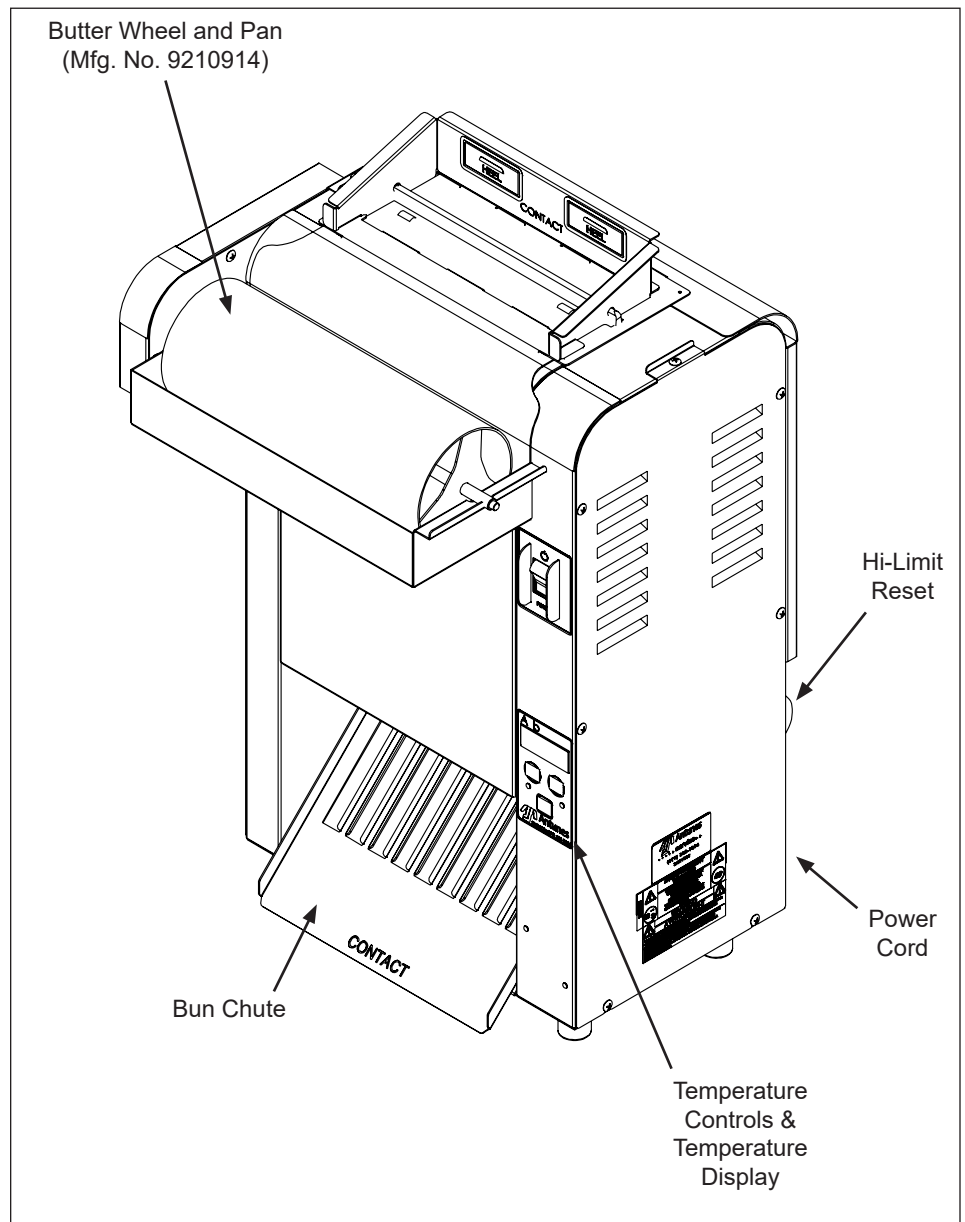

Figure 4. VCTM-2 Toaster

### Light/Dark Setting

The toaster has a Light/Dark adjustment setting that allows you to adjust the toast quality as the toaster is running.

While the toaster is in USE mode, press the UP or Down arrow buttons to adjust the Light/Dark setting.

The default setting is D0.

Light 10 is the lightest setting

Dark 10 is the darkest setting.

## Viewing Settings

To view the toaster settings press and hold the Menu button (Figure 5) for approximately 5 seconds. The unit beeps and shows the settings in the following order, displaying the value in column 1 first, then the actual setting.

Display Shows	Setting Description
°A - ° F	A Platen current temperature*
b° - ° F	B Auxiliary heater current temperature*
SPEd	Speed of belts
Unit	Current temperature Unit
Er	Error Code
Et - d	Elapsed Time of toaster usage
Int ° F	Internal toaster Temperature
PL	Power Line Voltage

\* The first circles shown in these values represent the Platen indicator lights. The temperature unit will be shown as ° F or ° C depending on the Unit setting.

## Changing Settings

The only settings that can be changed on the toaster are:

- A Platen setpoint temperature
- B Platen setpoint temperature
- Speed
- Unit

To change these settings, follow these steps.

1. With the toaster turned off, press and hold the Menu button and turn the toaster on. Continue holding the Menu button until the unit beeps and EnA appears on the display. Release the Menu button.
2. Press the Menu button again. The toaster shows °A - ° F (A Platen) and then shows the current A Platen setpoint value. Use the ▲ and ▼ buttons to change the value as needed.
3. Press the Menu button to move to the B Platen setting. Edit as needed.
4. Press the Menu button to move to the SPEd (Speed setting). Edit as needed.
5. Press the Menu button to move to the Unit setting. Edit as needed.

The settings are saved each time you press the Menu button and move to the next value. The toaster exits programming mode after 30 seconds of inactivity.

## Factory Reset

To reset the toaster to the original factory settings:

1. Turn the toaster off.
2. Press and hold both the ▲ and ▼ buttons and turn the toaster on, continuing to hold the ▲ and ▼ buttons until the unit beeps and FR (Factory Reset) appears on the display.
3. Release the buttons.

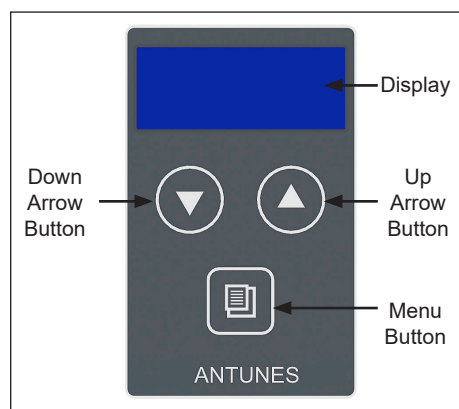

Figure 5. Control Panel and Display

## Hi-Limit Reset Button

A Hi-Limit Control turns off power to the unit if it overheats. To reset the control, allow the unit to cool, then locate the Reset Button at the rear of the unit. Remove the black protective cap, press the Reset Button, and reinstall the protective cap (Figure 4).

**NOTE:** If the Hi-Limit requires continuous resetting, contact Antunes Technical Service.

## Fault Codes

The table below describes error codes and the corrective action.

Error #	Cause/Description	Corrective Action
1	Cannot communicate with thermocouple A/D converter (U3). Potentially failed PC Board Component.	Turn unit off and back on again. If error persists, this may indicate a failed PC Board component. Contact Antunes Technical Service for assistance.
2	Cannot detect power line zero cross. Potentially failed PC Board Component.	
3	Calibration check sum. Potentially failed PC Board Component.	
4	Microprocessor I2C buss communications error. Potentially failed PC Board Component.	
5	Microprocessor I2C buss communications error. Potentially failed PC Board Component.	
6	Cannot communicate with Fram (U9). Potentially failed PC Board Component.	
7	Cannot communicate with TMP75 (board temp sensor) (U4). Potentially failed PC Board Component.	
8	On-board voltage reference in thermocouple circuit failed (U1). Potentially failed PC Board Component.	
9	Not used.	Not Used
10	Board temp sensor exceeds 158° F.	Verify vents on toaster are unblocked and not near other heated appliances. If error persists, contact Antunes Technical Service for assistance.
11	Main Hi Limit tripped.	Reset Hi Limit, turn unit off and back on again. If error persists, contact Antunes Technical Service for assistance.
12	Cannot measure power line voltage Failed on-board transformer used for power control (T1).	Turn unit off and back on again. If error persists, contact Antunes Technical Service for assistance.
13	USB port voltage below 4.5V - Something plugged into USB port.	Remove anything connected to the USB port, turn unit off and back on again. Turn unit off and back on again. If error persists, contact Antunes Technical Service for assistance.
14	Main platen has not reached set point within 20 minutes.	Turn unit off and back on again. If error persists, contact Antunes Technical Service for assistance.
15	Main platen has exceeded 650° F.	
16	Main platen has fallen 50°F below set point after Ready state.	
17	Main thermocouple failed (open).	
18	Aux has fallen 50°F below set point after Ready state; will clear from display if temperature recovers; error is logged into memory.	Make sure front and rear covers are in proper position. Turn unit off and back on again. If error persists, contact Antunes Technical Service for assistance.
19	Auxiliary Heater exceeds 525° F.	
20	Auxiliary Heater does not reach set point within 20 minutes.	
21	Auxiliary thermocouple failed (open).	Turn unit off and back on again. If error persists, contact Antunes Technical Service for assistance.
22	Auxiliary Hi Limit (hardware circuit trips at 550°F which turns off contactor; ER22 then shows within 2 seconds).	Turn unit off and back on again. If error persists, contact Antunes Technical Service for assistance.
23	Cannot communicate with motor microprocessor (U13).	Turn unit off and back on again. If error persists, this may indicate a failed PC Board component. Contact Antunes Technical Service for assistance.
24	Motor stopped.	Make sure no buns are stuck in conveyors or any obstructions around conveyors. Turn unit off and back on again. If error persists, contact Antunes Technical Service for assistance.

# Maintenance

## Daily Cleaning

### **WARNING**

Turn the power off, unplug the power cord, and allow the unit to cool to room temperature before performing any service or maintenance.

1. Turn the power OFF, unplug the power cord, and clean the release sheet and belts wraps while they are warm.

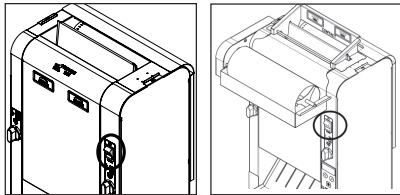

Non-Butter Wheel Unit Butter Wheel Unit

2. Put on heat-resistant gloves. Remove the Bun Feeder and Bun Chute.

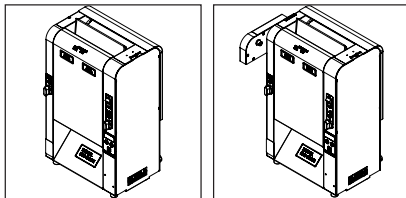

Non-Butter Wheel Unit Butter Wheel Unit

3. Take the Bun Feeder and Bun Chute to the sink and wash, rinse, and sanitize.

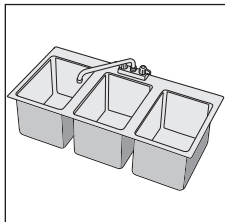

4. Remove the release sheet and place it on a clean, flat dry surface.

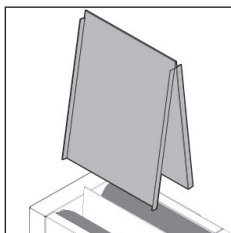

5. Inspect the release sheet and belt wraps. Replace if they are torn, damaged, or have excessive buildup.

6. Spray the silver side of the release sheet with Sink Detergent Solution and wipe with a clean, sanitizer-soaked towel. Rinse the silver side of the Release Sheet with a separate, clean sanitizer-soaked towel.

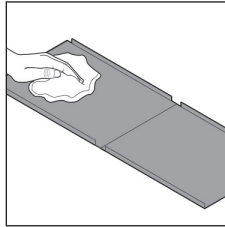

7. Flip the release sheet over and spray the black side with Sink Detergent Solution and wipe with a clean, sanitizer-soaked towel. Rinse the black side of the release sheet with a separate, clean sanitizer-soaked towel. Discard the soiled towel into the soiled towel bucket after use. Allow to air dry.

8. Open the front conveyor cover and firmly wipe the belt wrap from left to right and top to bottom with a clean, sanitizer-soaked towel sprayed with an approved Degreaser solution. Rinse the belt wrap from left to right and top to bottom with a separate, clean sanitizer-soaked towel.

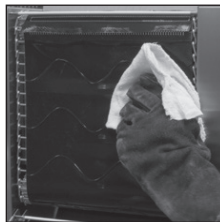

9. Close the front conveyor cover, open the rear conveyor cover and clean the belt wrap following step 8. Discard the soiled towels into the soiled towel bucket after use.

10. Close the rear conveyor cover. Plug in the power cord, turn the unit, allow belt to make a 1/2 revolution, then turn the unit OFF and unplug the unit.

11. Open the rear conveyor cover again and clean the newly exposed section of the belt wrap from left to right and top to bottom with a clean, sanitizer-soaked towel sprayed with degreaser solution. Rinse the belt wrap from left to right and top to bottom with a separate, clean, sanitizer-soaked towel.

12. Close the rear conveyor cover, open the front conveyor cover and clean the belt wrap following step 11. Discard the soiled towels into the soiled towel bucket after use. Close the front conveyor cover.

13. Wipe down the exterior of the toaster with a clean, sanitizer-soaked towel sprayed with a Degreaser solution. Rinse the exterior toaster with a separate, clean sanitizer-soaked towel. Discard the towel into the soiled towel bucket after use.

14. The release sheet has folded gutters to prevent debris migration onto the platen. Prior to installing the sheet, fold the gutters 90 degree if needed. Install the release sheet by draping it over both sides of the platen with the black side facing out.

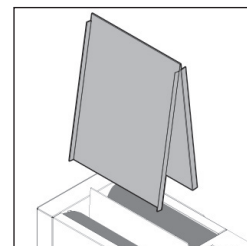

**NOTE:** The release sheet is not reversible, the black side should always be facing out.

15. Reinstall the Bun Chute through the front of the toaster. Hang the back of the Bun Chute on the rear Conveyor Cover hinge. See Figure 2 on page 5. Reinstall the Bun Feeder.

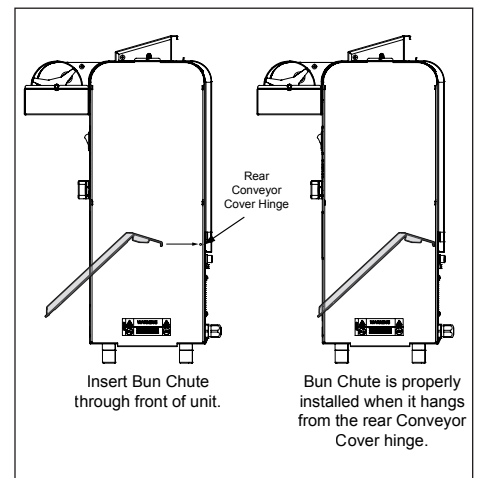

16. Plug the toaster in and turn the power switch to ON.

## Quarterly Cleaning

1. Turn the power OFF, unplug the power cord, and allow the unit to cool before proceeding.

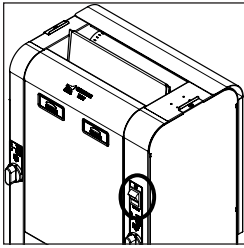

2. Put on heat-resistant gloves and remove the Bun Feeder and set the bun thickness compression knobs to 6 & 6.

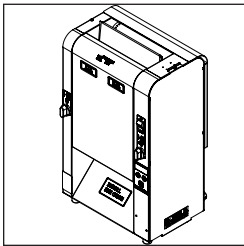

3. Open both conveyor covers (rear and front). Disconnect the clips on the inside part of the Belt Wraps from the Conveyor Belt Chain.
4. Remove the belt wraps and inspect both sides of the belt wraps for damage to the flap, ribs, or silicone surface. Replace any damaged belts.



5. Clean both conveyor belt chains (rear and front) with a non-scratch scouring pad sprayed with degreaser solution. Rinse with a separate, clean, sanitizer-soaked towel.

**NOTE:** Do not spray the toaster with water or cleaning product. This can damage electrical components.

6. Close both conveyor covers. Plug in the power cord, turn the unit on, allow belt to make a 1/2 revolution, then turn the unit OFF and unplug the unit.

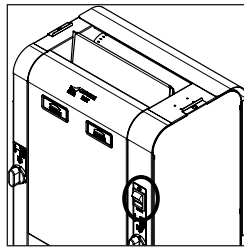

7. Open both conveyor covers again and clean the newly exposed section of the conveyor belt chains from left to right and top to bottom with a non-scratch scouring pad sprayed with a Degreaser solution. Rinse the belt wrap from left to right and top to bottom with a separate, clean, sanitizer-soaked towel.

Wipe down the belt wraps with a clean, sanitizer-soaked towel and allow to air dry before installing.



8. Install the belt wraps around the conveyor belt chains under the support rods, making sure the flap is pointing down.



**NOTE:** Make sure the Belt Wraps are installed under the support rods.

9. Close the conveyor covers and reinstall the Bun Feeder.

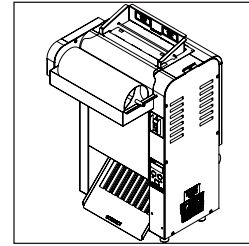

10. Set the bun thickness compression knobs back to their normal settings. It is acceptable to adjust the bun thickness setting as needed to achieve the desired quality toast and bun compression.
11. Plug the toaster in and turn the power switch to ON.

## Replacing the Belt Wraps

(Replacement as Needed)

### **! WARNING**

Turn the power off, unplug the power cord, and allow the unit to cool to room temperature before performing any service or maintenance.

**NOTE:** Depending on toaster usage and how well they are cleaned daily will determine the lifespan of the Belt Wraps

1. Turn the power off, unplug the power cord, and allow the unit to cool before proceeding.
2. Put on heat-resistant gloves. Remove the Bun Feeder, Release Sheet, and Bun Chute and set aside (Figure 1).
3. Set the Bun Thickness Compression Knobs to 6. Open both Conveyor Covers.
4. If necessary, remove both existing Belt Wraps. Lift the flap on the Belt Wrap and disconnect the Belt Wrap hooks from the Conveyor Belt Chain. Discard used Belt Wraps.
5. Wipe the belts with a clean, sanitizer-soaked towel.
6. Install the new Belt Wraps onto the toaster under the support rods, making sure the flap is pointing down (Figure 2).
7. Connect the Belt Wrap hooks to the Conveyor Belt Chain, ensuring all hooks snap into place (Figure 6, Figure 7, Figure 8).

**NOTE:** Install the hooks on a smaller link/gap on the conveyor chain belt to ensure better performance.

**NOTE:** Make sure the Belt Wraps are installed under the support rods.

8. Close the Conveyor Covers.
9. Reinstall the Release Sheet, Bun Chute, and Bun Feeder and return the toaster to operation.



Figure 6. Replacing Belt Wraps



Figure 7. Connecting Belt Wrap hooks



Figure 8. Connecting Belt Wrap hooks

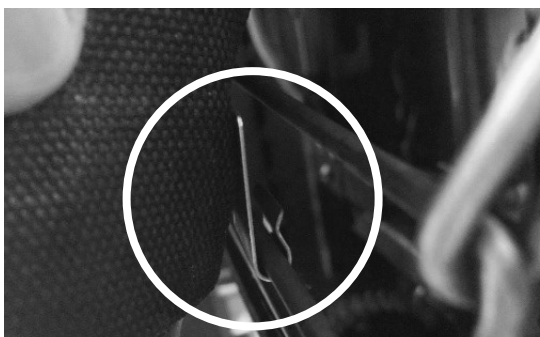

Figure 9. Check hooks snap into place

## Checking the Conveyor Belt Chains

### Measuring Conveyor Belt Chains

1. Turn the unit off, unplug the power cord, and allow the unit to cool.
2. Remove the Bun Feeder and Bun Chute (Figure 2). Set the Bun Thickness Compression Knobs to 6 & 6.
3. Open both Conveyor Covers.
4. Remove the Belt Wraps and set aside (Figure 5).
5. Facing the toaster, locate the approximate center-point of the Conveyor Belt Chain.
6. Pull the chain away from the edge of the toaster (Figure 10).
7. Measure the distance from the frame of the unit and the chain. A U.S. Dime (1.8 cm) can be used for the measurement (Figure 10).
8. If the gap is 2 times wider than the coin or larger than 3.6 cm, remove one 1/2" link as described below.
9. Disconnect the chain by squeezing any two links together and unhook the links from each other (Figure 11). Needle-nose pliers may be used.

**NOTE:** There are two small 1/2" links on each side of the Conveyor Belt Chain. The rest are large 3/4" links.

10. Remove one 1/2" link from the chain.
11. Reassemble the chain onto the sprockets as described in the Replacing Conveyor Belt Chains section of this manual.
12. Measure the gap again with the coin. The coin should fit snugly between the chain and frame.
13. Check the opposite side of the toaster using the same steps.
14. When finished, reassemble the unit and return to operation.

**NOTE:** If the ends of the Conveyor Belt Chain cannot be connected, remove an additional small 1/2" link and install a large 3/4" link in its place.

## Replacing Conveyor Belt Chains

1. Turn the power off, unplug the power cord, and allow the unit to cool before proceeding.
2. Remove the Bun Chute and set the Compression Control Knobs to 6 & 6.
3. Open both Conveyor Covers.
4. Remove both Belt Wraps and set aside.
5. Disconnect the Conveyor Belt Chain by squeezing any two links together and unhook both ends of one link (Figure 11). Repeat on other side.
6. Place the new chain on the top sprockets with hook ends down.
7. Wrap the chain around the top and lower sprockets. Hook both ends together. Repeat on other side.

**NOTE:** Install the Conveyor Belt Chains under the upper and lower Support Rods.

8. If the Belt Wraps are in good condition, reinstall. Otherwise install new Belt Wraps.
9. Close the Conveyor Covers, set the Bun Thickness Compression Knobs back to their normal settings and reinstall the Bun Feeder and Bun Chute.



Figure 10. Measuring Conveyor Belt Chain

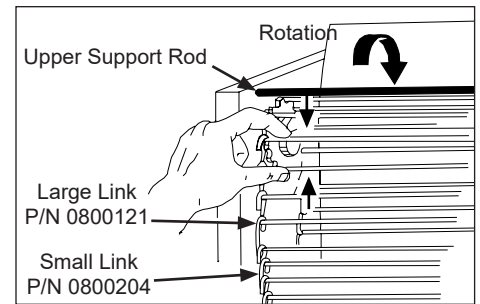

Figure 11. Removing Conveyor Belt Chain

# Troubleshooting

Problem	Possible Cause	Corrective Action
No Control Display	Power cord not plugged in	Plug power cord into the proper electrical outlet.
	Circuit breakers turned off or tripped. Damaged electrical outlet, plug, or cord. Power switch damaged	Reset circuit breakers. If they trip again, check the power cord, plug, and outlet for damage. Contact Antunes technical service for assistance.
	Power Switch not turned on or is faulty.	Turn the unit off and then on again. If the problem persists, contact Antunes technical service for assistance.
	Faulty Transformer	
Conveyor does not rotate	Conveyor Belt/Chain has stretched. Chain skipping on sprockets.	Measure and adjust the conveyor belt chains as described in the Maintenance section of this manual.
	Loose setscrew on one of the drive sprockets	Contact Antunes Technical Service for assistance.
	Motor Drive Chain loose	Contact Antunes Technical Service for assistance.
	Internal part /object interfering within conveyor system	Check for interference & clear up as necessary.
Conveyor(s) skips or hesitates	Conveyor chains loose.	Measure and adjust the conveyor belt chains as described in the Maintenance section of this manual.
	Belt wrap clip not attached.	Verify both clips on each belt wrap are attached, reattach if necessary.
	Loose or misaligned sprocket	Contact Antunes Technical Service for assistance.
	Motor drive chain loose or stretched	Contact Antunes Technical Service for assistance.
	Drive motor(s) have failed	Contact Antunes Technical Service for assistance.
Buns not toasting adequately	Compression settings are incorrect.	Use recommended setting or adjust compression knobs as needed to achieve desired toast quality.
	Release sheet is worn or needs cleaning.	Inspect release sheet for cleanliness, worn spots, wrinkles, or tears. Clean or replace release sheet as described in the Maintenance section of this manual.
	Platen has butter/debris buildup.	Clean Platen as described in the Maintenance section of this manual.
	Light/Dark setting needs to be adjusted.	Adjust light/dark setting. See Operation section of this manual.
Crowns and/or Heels must be forced into the toaster. Buns sticking and burning.	Belt wraps are dirty, worn or damaged.	Clean or replace Belt Wraps as described in the Maintenance section of this manual.
	Platen has butter/debris buildup.	Clean Platen as described in the Maintenance section of this manual.
	Release sheet is dirty, worn or damaged.	Clean both sides or replace release sheet as described in the Maintenance section of this manual.
	Conveyor Chains loose.	Adjust the conveyor belt chains as described in the Maintenance section of this manual.
	Drive motor stalls intermittently.	Contact Antunes Technical Service for assistance.
	Compression settings are incorrect.	Use the recommended settings or adjust as needed to achieve desired toast quality.
	Buns are not inserted into the toaster properly.	Insert Crowns in front conveyor with and Heels in rear conveyor. Cut side of buns need to face the platen.
Toaster making unusual sounds	Fan needs to be cleaned or replaced.	Clean fan as described in the Maintenance section of this manual or contact Antunes Technical Service for assistance.
	Conveyor belt chains have stretched or adjusted incorrectly.	Adjust the conveyor belt chains as described in the Maintenance section of this manual.
	Motor Drive chain needs lubrication.	Lubricate chain.
	Conveyor shaft bearing is binding.	Contact Antunes Technical Service for assistance.
Buns getting caught in bun chute area	Bun chute installed incorrectly	Reinstall Bun chute correctly.
Toaster displays ERR 10.	Internal temperature of control compartment exceeded 160° F.	Verify fan intake on back of toaster is clean, not blocked and has proper spacing. Clean cooling fan if needed, if not rotting, contact Antunes Technical Service. Check if cooling fan is functioning. If not, replace fan..



# Replacement Parts

## Parts List

(See Exploded Views for more information)

<b>NOTICE</b>
Use only genuine Antunes replacement parts in this unit. Use of parts other than those supplied by the manufacturer will void the warranty.

Item No.	Part #	Description	Qty.
1	7001135	Conveyor Belt Assembly 37/2	2
3	0022694	Tensioner Bracket Weldment - Right	2
4	0507840	Tensioner Bracket Weldment - Left	2
5	0021959	Cam Weldment	2
6	7001269	Conveyor Cover Weldment (Mfg. No. 9210914 Only)	1
	7001526	Conveyor Cover Weldment (Mfg. No. 9210916)	2
	0021961	Conveyor Cover Weldment (Mfg. No. 9210959, 9210960, & 9210983 Only)	2
7	7001540	Bun Chute Weldment	1
8	0022194	End Hsg Weldment	1
9	0022195	Control Housing Weldment	1
10	0022295	Base Weldment	1
11	7001734	Bun Feeder Accessories Kit	1
12	0024060	Weldment, Slide Shield - Crown	2
13	0506767	Weldment, Slide Shield - Heel	2
14	7001266	Weldment, Butter Wheel Roller (Mfg. No. 9210914 Only)	1
15	7001270	Weldment, Conveyor Cover Rear (Mfg. No. 9210914 & 9210916 only)	1
16	7001268	Platen, Grill 200V/1900W	1
17	040P138	Lock-Nut, Conduit-1/2" Npt	1
18	040P265	Bushing, Shorty 3/8"	4
19	0400315	Strain Relief-Cord Connector	1
20	0400432	Bushing, Open/Closed	1
21	0504321	Spacer 0.503 X 0.69 X 0.06"	1
22	0013412	Inner Tensioner Spring Assembly	4
23	7001006	Retainer, Bearing	5
24	0507327	Butter Wheel Housing (Mfg. No. 9210914 Only)	1
25	0507500	Retainer, Bearing	1
26	7001532	Panel, Control (Mfg. No. 9210916, 9210959, 9210960 & 9210983 Only)	1
27	0504945	Panel, End Housing (Mfg. No. 9210914 Only)	1
28	0507509	Aux. Heater Retainer Clip (Mfg. No. 9210914 & 9210916 Only)	2
29	7001265	Pan, Butter (Mfg. No. 9210914 Only)	1
30	0507556	Panel, Electrical	1
31	0507557	Bracket, Contactor	1

Item No.	Part #	Description	Qty.
32	0507558	Bracket, Thermocouple (Mfg. No. 9210914 & 9210916 Only)	1
33	7001529	Drive chain Tensioner	1
34	2150414	Idler Shaft	1
35	0600143	Spring, Compression Setting	1
38	0800458	Rod, Support	4
39	0800460	Shaft, Drive	2
40	0800900	Rod, Pivot, 3/16 O.d.	2
41	100P900*	Label - Warning	1
42	1001181	Label, Crown (Mfg. No. 9210916, 9210959, 9210960 & 9210983 only)	2
43	1001551	Label, Install	1
44	1002935	Label, Power Switch	1
45	1002662	Label, Wiring Diagram (Mfg. No. 9210914 & 9210916 only)	1
	1001665	Label, Wiring Diagram (Mfg. No. 9210959, 9210960 & 9210983 only)	1
47	1002696	Label, Control	1
48	1031295	Spec Label Mfg. No. 9210914	1
	1031297	Spec Label Mfg. No. 9210916	1
	1031369	Spec Label Mfg. No. 9210959	1
	1031373	Spec Label Mfg. No. 9210960	1
	1031503	Spec Label Mfg. No. 9210983	1
49	2070135	Coupler (Mfg. No. 9210914 Only)	4
50	210K230	Bumper, Recess W/Washer	4
52	2100379	Rail, Slide	2
53	211P127	Ring, Retaining	4
54	2120147	Spacer	4
55	7001537	Drive Sprocket Kit	1
56	7001330	Chain, Drive	1
57	7000207	Sprocket, 25B28 1/2" Bore Stepped Tooth	8
58	2150212	Sprocket, 25B12 1/2" Bore (Mfg. No. 9210914)	1
59	2150214	Sprocket, 25B30, 1/2" Bore (Mfg. No. 9210914)	1
60	7001531	Push on Knob Kit	1
61	2150251	Sprocket, 25B14 3/8" Bore	1
62	7000296	Bearing Kit	6
64	2150401	Chain, Drive (64 Links) (Mfg. No. 9210914 Only)	1
65	7001530	Motor, 230V	1
66	7001115	Idler Bearing Retainer	1
67	2150415	Coupler	1
68	7000296	Bearing, 1/2IDx1-1/8OD	1
69	2150419	Shaft Idler with Pin (Mfg. No. 9210914 Only)	1
70	2150420	Shaft, Drive (Mfg. No. 9210914 Only)	1
71	218P145*	Cover, Bumper	4
72	300P124*	Ring, Retaining 3/8"	1

# Replacement Parts

## Parts List

(See Exploded Views for more information)

Item No.	Part #	Description	Qty.
73	303P115*	Cotter Pin-1/16"	1
74	303P133*	Pin, Clevis	1
75	306P102*	Washer, Int. Tooth #6	1
76	306P105*	Screw, Mach. #6-32 X 1/2"	1
77	308P115*	Screw, Mach. #8-32 X 9593/8"	1
78	308P124*	Screw, Mach One-Way #8-32	1
79	308P143*	Nut, Hex 'Keps' #8-32	1
80	308P157*	Screw, Tap 8-32 X 3/8"Lg	1
81	308P203*	Screw, Tap 8-32 X 3/8" W/Int. Tooth Washer	1
82	3080341	Screw, #8-32 X 1.5 LG	4
83	325P104*	Washer, Flat 1/4" S/S	1
84	325P203*	Washer, Spring Steel Single-Wave	1
85	0500464	Bearing Spacer	1
86	7001440	Fan, Axial - 230V, Metal Housing & Imp	1
87	7001527	Cap-Mp, Motor Run	1
88	7001580	Switch, Rocker	1
89	7001144	Thermostat, Hi-Limit 700°F	1
90	7001259	Aux Heater, 200Vac, 550W (Mfg. no. 9210914, 9210916 Only)	2
91	7001293	Thermocouple Type "K" (Open End)	1
92	7001428	Line Filter (Mfg. no. 9210914, 9210916, 9210959 & 9210983 Only)	1
93	7001017	Contact, 2 Pole No	1
94	7001142	Relay, Solid State Dual Pole W/ Conn-Recept	1
95	4060466	C-Clip (Mfg. No. 9210914 Only)	4
96	7001429	Varistor Board	1
97	7002037	Black Wavy Cleated Silicone Belt Wrap (Mfg. no. 9210914, 9210916 Only)	1
98	7001168	Platen Cover Sheet (3 pack)	1
99	7001261	Asy-PCB, VCT Mini Power Board	1
100	7001260	Asy-PCB, VCT Mini Control Board	1
101	3100228	SCR, SHLDR #10-32 x 1.125	1
102	7001267	End Housing Cover Assy. (Mfg. No. 9210914 Only)	1
103	306P130*	Nut, Hex keps #06-32 Steel; Zinc Plated	1

Item No.	Part #	Description	Qty.
104	0700982	Power Cord (Mfg. no. 9210914, 9210916 & 9210959 Only)	1
	0700976	Power Cord (Mfg. No. 9210960 Only)	1
	0701057	Power Cord (Mfg. No. 9210983 Only)	1
106	7001595	Sprocket, 25B14 1/2 Bore	1
107	0600179	Extension Spring	4
108	0800461	Idler Shaft	1
109	3380116	Screw, Shoulder 3/8-16"X3/8 W/ 1/2 Shoulder	4
110	3100146	Nut, Hexkeys #10-32 Steel; Zinc Plated	24
* Items available in packages of 10 (ten)			

# Exploded Views

## Exploded View #1

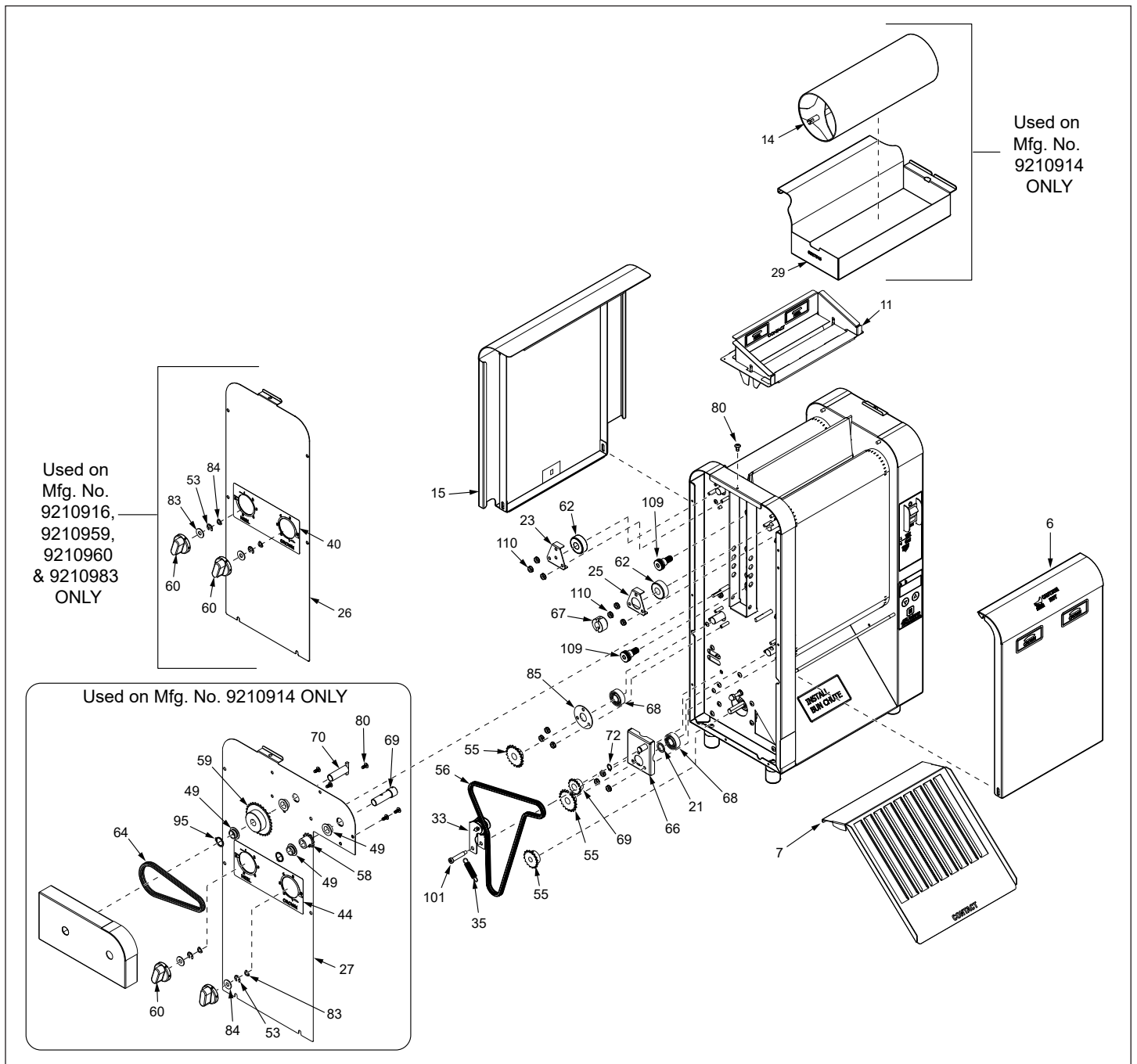

# Exploded Views

## Exploded View #2

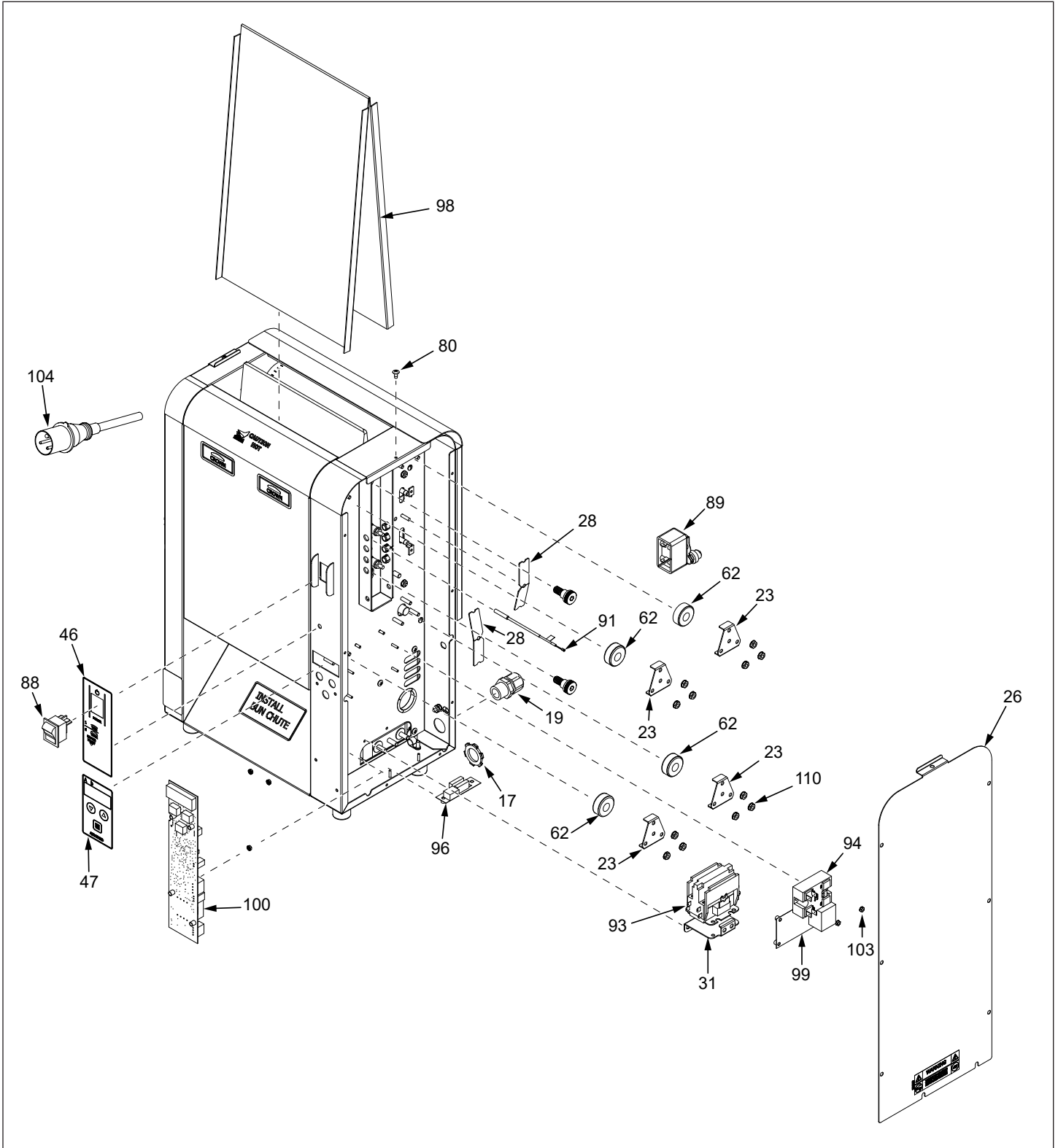

# Exploded Views

## Exploded View #3

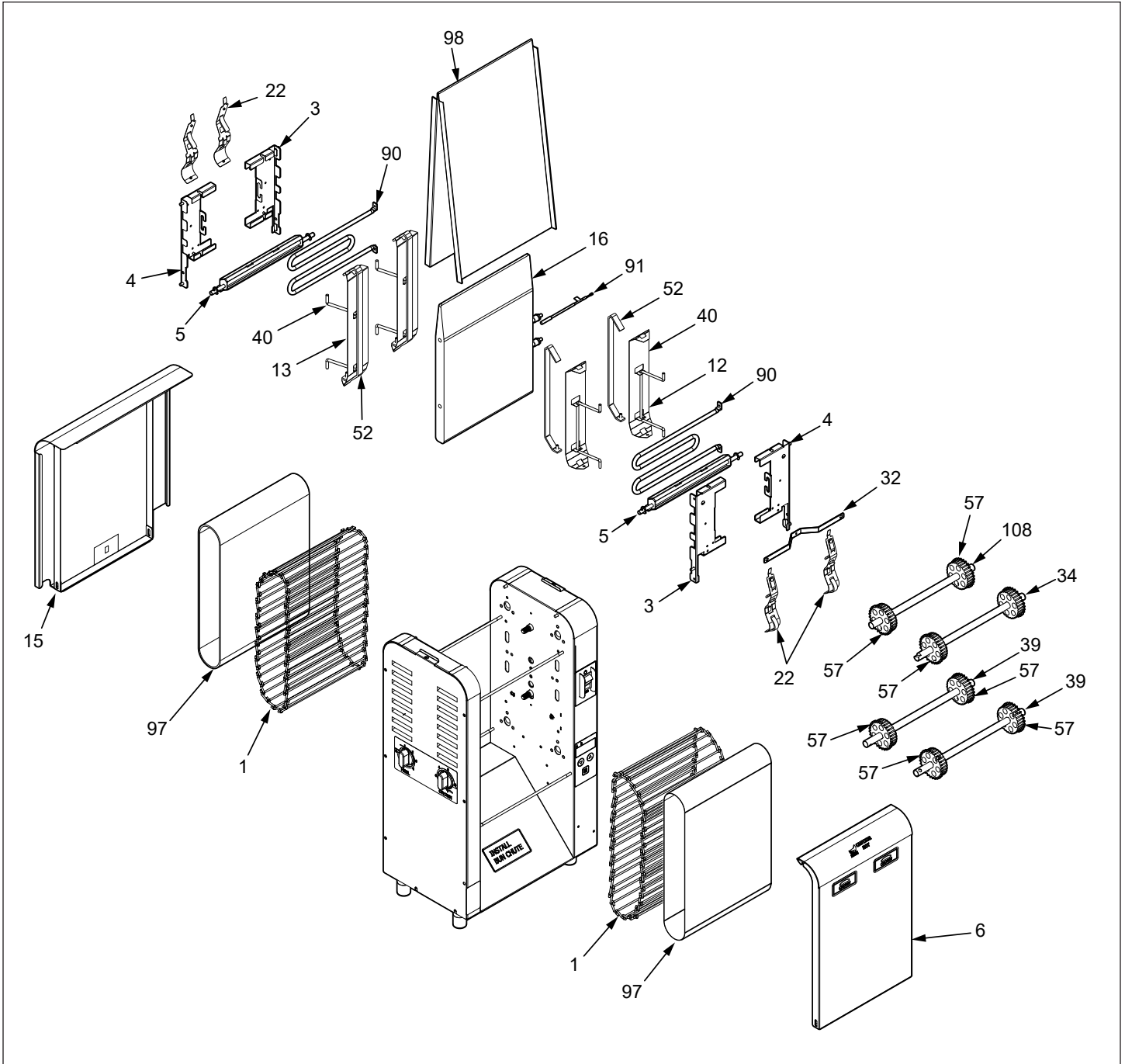

# Exploded Views

## Exploded View #4

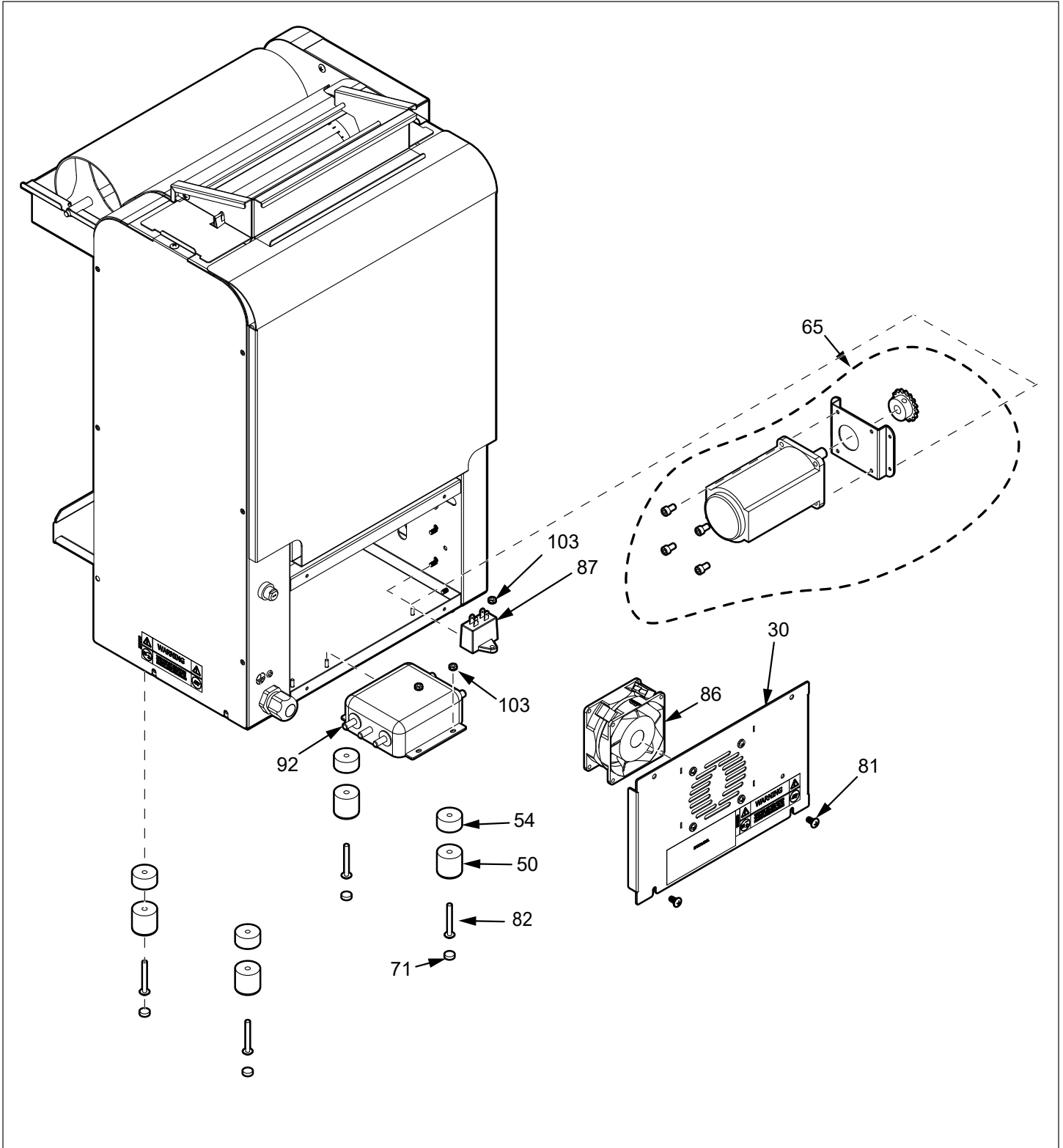





## Limited Warranty

Equipment manufactured by Antunes has been constructed of the finest materials available and manufactured to high quality standards. These units are warranted to be free from electrical and mechanical defects for a period of one (1) year from date of purchase under normal use and service, and when installed in accordance with manufacturer's recommendations. To insure continued operation of the units, follow the maintenance procedures outlined in the Owner's Manual. During the first 12 months, electromechanical parts, non-overtime labor, and travel expenses up to 2 hours (100 miles/160 km), round trip from the nearest Authorized Service Center are covered.

1. This warranty does not cover cost of installation, defects caused by improper storage or handling prior to placing of the Equipment. This warranty does not cover overtime charges or work done by unauthorized service agencies or personnel. This warranty does not cover normal maintenance, calibration, or regular adjustments as specified in operating and maintenance instructions of this manual, and/or labor involved in moving adjacent objects to gain access to the equipment. This warranty does not cover consumable/wear items. This warranty does not cover damage to the Load Cell or Load Cell Assembly due to abuse, misuse, dropping of unit/shock loads or exceeding maximum weight capacity (4 lbs). This warranty does not cover water contamination problems such as foreign material in water lines or inside solenoid valves. It does not cover water pressure problems or failures resulting from improper/incorrect voltage supply. This warranty does not cover Travel Time & Mileage in excess of 2 hours (100 miles/160 km) round trip from the nearest authorized service agency.
2. Antunes reserves the right to make changes in design or add any improvements on any product. The right is always reserved to modify equipment because of factors beyond our control and government regulations. Changes to update equipment do not constitute a warranty charge.
3. If shipment is damaged in transit, the purchaser should make a claim directly upon the carrier. Careful inspection should be made of the shipment as soon as it arrives and visible damage should be noted upon the carrier's receipt. Damage should be reported to the carrier. This damage is not covered under this warranty.
4. Warranty charges do not include freight or foreign, excise, municipal or other sales or use taxes. All such freight and taxes are the responsibility of the purchaser.
5. THIS WARRANTY IS EXCLUSIVE AND IS IN LIEU OF ALL OTHER WARRANTIES, EXPRESSED OR IMPLIED, INCLUDING ANY IMPLIED WARRANTY OR MERCHANTABILITY OR FITNESS FOR A PARTICULAR PURPOSE, EACH OF WHICH IS HEREBY EXPRESSLY DISCLAIMED. THE REMEDIES DESCRIBED ABOVE ARE EXCLUSIVE AND IN NO EVENT SHALL ANTUNES BE LIABLE FOR SPECIAL CONSEQUENTIAL OR INCIDENTAL DAMAGES FOR THE BREACH OR DELAY IN PERFORMANCE OF THIS WARRANTY.

The warranty does not extend to:

- Damages caused in shipment
- Installation of electrical service
- Installation, calibration, or adjustment
- Normal maintenance outlined in this manual
- Consumable parts such as egg rings, gaskets, rubber feet, labels, O-rings, light bulbs, etc.
- Malfunction resulting from improper service or maintenance
- Damage caused by improper installation, improper use, abuse, or careless handling
- Damage from moisture coming in contact with electrical components
- Damage from tampering with, removal of, or changing preset controls or safety devices
- Damage caused by parts or components not provided by Antunes



**Corporate Headquarters**  
Carol Stream, IL, USA  
Phone: +1.630.784.1000  
Toll Free: +1.800.253.2991  
Fax: +1.(630).784-1650

**China Facility**  
Suzhou, China  
Phone: +84.512.6841.3637  
Fax: +86.512.6841.3907

**India Facility**  
Chennai, India  
Phone: +91.44.25532212  
Fax: +91.44.25532415