



GOLDEN BROWN FINISH

The Vertical Contact Toaster VCT-2 is the perfect fit for any size commercial kitchen, with an overall footprint of less than 1 square foot – 60% smaller than the standard VCT model.

The smaller size does not come at the expense of toast quality or capability. It features a dual-sided platen, two toasting lanes, and a toast time of just 15 seconds. With independent compression settings and a digital controller, the VCT-2 allows operations to easily adjust toast quality for a variety of different bread products.



Higher Capacity or Dual-Sided Platen

Vertical Contact Toaster has more capacity than conventional single-sided toasters, allowing operations to quickly serve fresh products to customers without making them wait



Adjustable Quality

Compression settings and platen temperatures are easily adjustable. Every bun can have a golden-brown finish without being flattened or marked.



Small Footprint

The upright design saves valuable counterspace, allowing it to easily integrate into any operation.

VCT-2 Vertical Contact Toaster

Vertical Contact Toaster | VCT-2

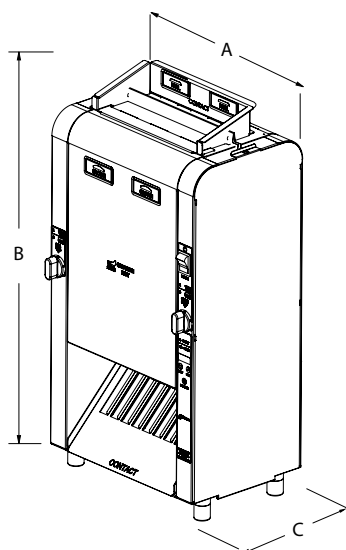

Features:

- Dual-sided platen for additional toasting capacity compared to conventional single-sided toasters.
- Small footprint saves valuable countertop space.
- Individual heel and crown compression.
- Digital controller to make quick adjustments to toast quality.
- Toasts multiple products, including white and wheat buns
- Belt wraps eliminate bun marking.
- Easy to operate and clean.
- Toasts product in 15 seconds (± 2 seconds).

VCT-2 (with belt wraps)

Electrical Ratings

Dimensions

Model & Mfg. No.	Capacity	Approvals	Plug	Volts	Watts	Amps	Hz.	Width	Depth	Height	Shipping Weight
VCT-2 9210907	15-sec. toast time		5-15P NEMA	120	1800	15	50/60	13" (330 mm)	10" (254 mm)	22" (559 mm)	67 lbs. (30.4 kg)

VCT-2 (without belt wraps)

VCT-2 9210955	15-sec. toast time		5-15P NEMA	120	1800	15	50/60	13" (330 mm)	10" (254 mm)	22" (559 mm)	67 lbs. (30.4 kg)
VCT-2 9210923	15-sec. toast time		IEC-309	230	1900	15	50/60	13" (330 mm)	10" (254 mm)	22" (559 mm)	67 lbs. (30.4 kg)